

SECTION IV
MAINTENANCE

SECTION IV

MAINTENANCE

4.1 GENERAL

The WJ-8615D Compact Receiver is designed to operate for extended periods of time with minimum routine maintenance. Cleaning, inspection and performance tests should be performed at regular intervals, consistent with the facility's normal scheduling and after repairs have been made.

4.2 CLEANING AND LUBRICATION

The unit should be kept free of dust, moisture, grease and other foreign matter to ensure trouble-free operation. Use low pressure air, if available, to remove accumulated dust from the interior of the receiver. A clean, dry cloth or soft bristled brush may also be used for this purpose. No lubrication is required.

4.3 INSPECTION FOR DAMAGE OR WEAR

Many existing or potential troubles can be detected by making a thorough visual inspection of the unit. For this reason, as a first step, a complete visual inspection should be made whenever the unit is inoperative. Inspect mechanical parts such as pin connectors and interconnecting cables for looseness, wear and other signs of deterioration. Plug-in sub-assemblies and modules should be checked to assure that they are properly inserted into their appropriate connector slots and making good electrical contact. Electronic components that show signs of deterioration, such as overheating, should be inspected and a thorough investigation of the associated circuitry should be made to verify proper operation. Often, damage due to heat is a result of other, less apparent problems in the circuit.

4.4 TEST EQUIPMENT REQUIRED

The test equipment listed in **Table 4-1** or their equivalents are required to perform the troubleshooting procedures, performance checks and alignment procedures that follows.

4.5 TROUBLESHOOTING PROCEDURES AND FAULT ISOLATION

Troubleshooting the WJ-8615D Compact Receiver can be performed by placing the receiver in its Standard Local Operation mode (refer to **paragraph 2.4.1**) or the Test Mode (refer to **paragraph 2.4.2**) and observing the receiver operation while in these modes. To eliminate external conditions as a possible cause of the malfunction, the equipment listed in **Table 4-1** should be utilized to inject the appropriate test signals and to monitor the results of the receiver outputs.

To monitor the overall receiver capability to produce an output signal at each rear panel connector, follow these steps.

1. Inject a 255.5550 MHz FM signal at -40 dBm with 30% peak deviation of the selected IF bandwidth into the RF input connector (J10) on the receiver rear panel.
2. Energize the receiver.
3. Refer to **paragraph 2.2.1** for an explanation of the signals present at each rear panel output connector.

The performance tests that follow and the Troubleshooting Table (**Table 4-2**) are provided as an aid for localizing the cause of a malfunction to a particular subassembly within the receiver. Reference should also be made to the receiver block diagrams provided in **Section III** of the WJ-8615D Instruction Manual and to the schematic diagrams provided in **Section VI**.

Table 4-1. Test Equipment Required

| Equipment | Description | Type |
|---|---|--|
| Autotransformer Digital Voltmeter RF Millivoltmeter | Variable High Impedance Calibrated in dB Probe "T" Adapter 50 Ω Termination | W5MT3W (General Radio) Fluke 8100A Boonton 92B Boonton 91-12F Boonton 91-14A Boonton 91-15A |
| AC Voltmeter Distortion Analyzer RF Analyzer | Wideband, High Impedance 550 kHz to 65 MHz Log Transmission, Plug In Log Reflection, Plug In | HP-400EL HP-334A Wiltron 640 Wiltron T50 Wiltron R50 |
| Oscilloscope Frequency Counter Feedthru Termination Signal Generator | DC to 35 MHz DC to 50 MHz 600 Ω 20 Hz to 1024 MHz, with Audio oscillator option | Tektronix T935 HP-5245L Tektronix 011-0092-00 HP-8640B Option 001, 002 |
| Signal Generator Sweep Generator Combiner Power Supply | 450 to 1230 MHz 1 to 1500 MHz 2 to 400 MHz 0 to 30 Vdc | HP-612A Wiltron 650 Olketron B-HJ-302G-1 HP-6216A HP3585 |
| Spectrum Analyzer | Display Section IF Section RF Section | HP-141T HP-8552B HP-8554B |
| Noise Figure Indicator Noise Source Attenuator Attenuator | 10 MHz to 40 GHz 10 MHz to 1.5 GHz 10 dB Coaxial 0 to 80 dB | Ailtech 7512-004 Ailtech 7615 AEL AFA-10 TF-10141 (WJ-SPD) |

Table 4-1. Test Equipment Required (Cont'd)

| Equipment | Description | Type |
|---|--|---|
| Post Amplifier Pulse Generator Computer Device | 21.4 MHz 10 mV to 12 V into 50 Ω IEEE-488 compatible ROM ROM Interface | TF-10142 (WJ-SPD) Data pulse 106A HP-9825A HP-98210A HP-98213A HP-98034A |
| Load | 50 Ω (Resistor, Fixed, Film: 1/4 W) | CF1/4-50 OHMS/J |
| Test Cable Test Cable Test Cable | | 30047 (WJ-SPD) 30054 (WJ-SPD) 30059 (WJ-SPD) |
| IF Filter Network Analyzer Transmission/Reflectance Bridge | 21.4 MHz, 60 kHz BW 500 kHz to 1.3 GHz 50 Ω | TF-15003-1 (WJ-SPD) HP-8505 HP-8502A |
| Function Generator Balanced Mixer | 1 μ Hz to 21 MHz 3 to 1000 MHz | HP-3325 M1A (WJ-SPD) |

NOTE

To prevent damage to the receiver circuitry, always de-energize the receiver before removing or installing any subassembly.

Table 4-2. WJ-8615D Troubleshooting Table

| Symptom | Probable Cause | Corrective Action |
|---|--|--|
| Receiver totally inoperative. Front panel blank, no signal at any output connector. | Fuse F1 blown. Defective power switch S1. Defective Power Supply. Defective Digital Control Section. | Locate and correct cause of blown fuse. Replace the fuse. Check operation of switch S1. Replace if defective. Refer to paragraph 4.6.1. Refer to paragraph 4.6.3 |
| Receiver front panel controls function but no signals at any output connector. | Defective Digital Control Section. | Refer to paragraph 4.6.4 |

Table 4-2. WJ-8615D Troubleshooting Table (Cont'd)

| Symptom | Probable Cause | Corrective Action |
|---|--|--|
| | Defective Synthesizer Section. | Refer to paragraph 4.6.4 |
| | Defective Converter (A1A13). | Refer to paragraph 4.6.2.5 |
| Receiver front panel indicators randomly illuminated. Front panel controls inoperative. Erroneous or non-existent signals at output connectors. | On microprocessor subassembly A1A3, IC's U3 and U4 not installed or installed in wrong socket. | Install U3 and U4 correctly. |
| Receiver operates normally. Front panel controls inoperative. Wideband IF Output normal; all other outputs inoperative. Malfunction occurs with all bandwidth selections. | Header U2 missing. Receiver is in remote mode. Defective Digital Control Section IF Bandwidth Filter subassembly (A1A12) defective. AM/FM Demodulator subassembly (A1A9) defective. | Install U2. Depress CONTROL, returning receiver to local mode. Refer to paragraph 4.6.3 Replace subassembly. Replace subassembly. |
| Wideband IF Output normal. All other outputs function on one or more, but not all bandwidths. | Defective Digital Control Section IF Bandwidth Filter subassembly (A1A12) defective. CW Demodulator/SW IF subassembly (A1A11) defective. | Refer to paragraph 4.6.3 Replace subassembly. Replace subassembly. |
| Switched IF Output inoperative, all other outputs function normally. | CW Demodulator/SW IF subassembly (A1A11) defective. | Replace subassembly. |
| FM Monitor Output inoperative, all bandwidths affected. FM Monitor Output inoperative, in one or more, but not all bandwidth selections. | Audio/Video subassembly (A1A10) defective. Defective Digital Control Section AM/FM Demodulator subassembly (A1A9) defective. | Replace subassembly. Refer to paragraph 4.6.3 Replace subassembly |
| No FM Video at the Switched Video Output when FM Detection is selected. FM Monitor output normal. | Defective Digital Control Section Audio/Video subassembly (A1A10) defective. | Refer to paragraph 4.6.3 Replace subassembly |

4.5.1 **DIAGNOSTIC TEST PROCEDURES**

Diagnostic testing is a built-in function of the WJ-8615D VHF/UHF Compact Receiver. It is designed to allow troubleshooting or fault analysis from the front panel. Refer to **paragraph 2.2.1** for a description of DIP switch S1 on the IEEE-488/Interrupt subassembly (A1A2) in order for the diagnostic test function to operate properly.

In the diagnostic test mode, the receiver has many of its software loops opened to aid maintenance personnel in ascertaining the cause of a particular fault. Before attempting to utilize the receiver diagnostics, power up receiver to verify that no error conditions exist as indicated in the front panel display. Refer to **paragraph 2.7** for a description of the error codes.

4.5.1.1 **Diagnostic Test Set-Up Procedures**

Apply power to the receiver while depressing the CONTROL pushbutton in. The display indicates "dEF oFF". Rotate the tuning wheel to "dEF oFF". Depress CHANGE until the display indicates "d1AG oFF". Rotate the tuning wheel to "d1AG on". Depress CONTROL, the front panel display is back to normal operation with the TEST LED illuminated. Switch position 8 of S1 is an over-ride utilized to turn the diagnostic test on within the receiver.

4.5.2 The following paragraphs describe each of the diagnostic tests and expected results. **Table 4-4** indicates the function of the front panel LED's and pushbuttons.

4.5.2.1 **Select Bandwidth** - Depress and hold this pushbutton in to indicate the position of the IF bandwidth filter (slot 1 through 5) and the filter size (kHz) in the display window. The -dBm display indicates the IF bandwidth code (refer to **Table 3-1**). A non-existent IF bandwidth filter is indicated as 0000.

4.5.2.2 **Manual Gain Control Test Mode** - In the Manual Gain Control Test mode, the operator may enter fixed attenuation ranging from 0 to 114 dB by utilizing the CHANGE ↑/↓ pushbuttons. The attenuation level is displayed in the -dBm display. Depress the MGC pushbutton as required to produce a front panel LED display reflecting the MCG LED illuminated and the CLV LED extinguished.

4.5.2.3 **MGC, CLV** - With these pushbuttons depressed and the corresponding LED's illuminated, utilization of the AM Detector is indicated in the -dBm display from 0 to 100%.

4.5.2.4 **AGC, CLV** - With these pushbuttons depressed and the corresponding LED's illuminated, relative signal strength is indicated in the -dBm display.

4.5.2.5 **AGC** - With this pushbutton depressed, the COR LEV display indicates a specific test code (see **Table 4-4**). The -dBm display indicates the value of that code. Utilize the CHANGE ↑/↓ pushbuttons to step through the tests.

Table 4-3. Test Codes and Values

The following tests are enabled only when the AGC LED is illuminated.

| Test Code (COR LEV) | Description | Value (-dBm) | Comments |
|---------------------|--|--------------|--|
| FA | Peak deviation of FM AC value | 0 - 255 | 127 typical with signal centered in IF. |
| Fd | FM DC level for FM Discriminator | 0 - 255 | |
| LG | LOG Detector (0 - 60 dB above noise floor) | 0 - 255 | |
| bc | Voltage equivalent of bandwidth select code. | 0 - 255 | Depress SELECT BANDWIDTH to step through bandwidths. Refer to Table 3-1 for specific codes. |
| 2L | 2nd LO tuning voltage at 5 MHz. | 0 - 255 | 100 to 140 typical |
| AP | AM Peak Detector level | 0 - 255 | |
| AA | AM AC modulation | 0 - 200 | 0 = 0%, 200 = 100% |
| XX | Normal COR operation | | |

NOTE

For the FA, Fd, LG, 2L and AP tests, a value indication at the extremes indicates a fault. Refer to the Performance Test **paragraph 4.6** to isolate the fault.

4.5.2.6 **AFC** - This pushbutton removes the ± 10 times the selected bandwidth limitation (**paragraph 2.4.1.8**), allowing the AFC circuitry to track from the lowest tuned frequency to the highest tuned frequency.

4.5.2.7 **BFO** - This pushbutton removes the software correction from the BFO circuitry, causing it to be open-looped. The BFO counter does not run during this test.

4.5.2.8 **TUNE LOCK** - Depressing this pushbutton indicates the frequency of the 1st LO Synthesizer from the microprocessor.

4.5.2.9 **FASTER** - Depressing this pushbutton indicates the frequency of the 2nd LO Synthesizer from the microprocessor.

4.5.2.10 **SLOWER** - Depressing this pushbutton indicates the frequency of the 3rd Synthesizer from the microprocessor.

Table 4-4. Diagnostic Tests

| MGC | AGC | CLV | Description of Test with LED Illuminated |
|------------------------|-----|-----------|---|
| ON | OFF | OFF | Provides operator with a selection up to 114 dB of attenuation. Refer to paragraph 4.5.2.2. |
| ON | OFF | ON | Utilization of AM Detector is indicated in the -dBm display. Refer to paragraph 4.5.2.3. |
| OFF | ON | ON | Provides signal strength indication in -dBm display. Refer to paragraph 4.5.2.4. |
| OFF | ON | OFF | COR LEV window displays a code described in Table 4-4. The -dBm display indicates the value for the specific code. Refer to paragraph 4.5.2.5 |
| AFC | | | Enables receiver to tune across entire frequency range. Refer for paragraph 4.5.2.6. |
| BFO | | | Removes software correction from BFO. Refer to paragraph 4.5.2.7. |
| Front Panel Pushbutton | | | Description of Test |
| TUNE LOCK | | | Provides 1st LO Synthesizer frequency from microprocessor. Refer to paragraph 4.5.2.8. |
| FASTER | | | Provides 2nd LO Synthesizer frequency from microprocessor. Refer to paragraph 4.5.2.9. |
| SLOWER | | | Provides 3rd Synthesizer frequency from microprocessor. Refer to paragraph 4.5.2.10. |
| CONTROL | | | Places receiver into the REMOTE mode. |

NOTE

The receiver should not be placed into the diagnostic operation mode if the IEEE-488 interface bus is utilized. Certain pushbutton sequences stop 488 operation.

4.5.3 RETURNING RECEIVER TO NORMAL OPERATION

To return the receiver to normal operation, depress the POWER on/off switch. Depress it again and the front panel display indicates normal operation with the TEST LED extinguished.

4.6 PERFORMANCE TESTS

The performance test procedures provided in this section may be utilized for periodic performance testing, as an aid in troubleshooting or as a performance test after repairs have been completed. These procedures should be executed only by skilled technicians, utilizing the equipment listed in **Table 4-1** or their equivalents.

Unless otherwise specified in a particular test procedure, the receiver controls should be set to the Standard Test Settings listed in **Table 4-5** for each of the performance tests.

Table 4-5. Receiver Standard Test Setting

| | | |
|--------------|-------------------------|--------------|
| Front Panel: | Frequency: | 255.5550 MHz |
| | Detect Mode: | AM |
| | Gain Mode: | AGC |
| | Bandwidth: | #3 |
| | Tuning Speed: | 1 kHz |
| | AFC: | OFF |
| | Audio Gain: | Midrange |
| | RF/IF Gain: | Maximum |
| | COR Level: | 00 |
| Control: | Local | |
| Rear Panel: | Line Audio Adjust (R1): | Midrange |

4.6.1 POWER SUPPLY TESTS

1. Prior to applying power to the receiver, check the line cord receptacle and the voltage selector switch (S2) as described in **paragraph 2.2.1.1**.
2. Connect the receiver to the Type W5MT3W Variable Autotransformer. Set the autotransformer output voltage to a voltage corresponding to the selected voltage by S2, described in step 1.
3. Apply power to the receiver by depressing the POWER switch. Note the power consumption, indicated by the Autotransformer wattmeter. The power consumption should be no greater than 35 watts. (If the FE-2 option is installed, power consumption should be no greater than 45 watts.)

4. Utilizing the Type 8100A Digital Voltmeter, measure the output voltage for the DC supplies at the test points listed in **Table 4-6A**. The measured voltage should fall within the limits specified in the table.

Table 4-6A. Power Supply Voltages

| Test Point | Supply | Limits |
|------------|--------|-----------------------|
| A1J2-2 | +15 | +15.00 \pm 0.75 Vdc |
| A1J12-9 | +5A | 5.00 \pm 0.25 Vdc |
| A1J2-4 | +5B | 5.00 \pm 0.25 Vdc |
| A1J2-3 | -15 | -15.00 \pm 0.75 Vdc |
| A1J6-3 | +5C | 5.00 \pm 0.25 Vdc |
| A1J6-4 | +5D | 5.00 \pm 0.25 Vdc |

5. Utilize the digital voltmeter to set the output of the autotransformer to 97.7 Vac rms and with the probe, measure and record the voltage of the DC supplies as indicated in **Table 4-6B**.

Table 4-6B. Power Supply Voltages

| Test Point | Supply | Limits |
|------------|--------|-----------------------|
| A1J2-2 | +15 | +15.00 \pm 0.75 Vdc |
| A1J2-3 | -15 | -15.00 \pm 0.75 Vdc |
| A1J12-9 | +5A | 5.00 \pm 0.25 Vdc |

6. Utilize the digital voltmeter to set the output of the autotransformer to 132.2 Vac rms and with the probe, measure and record the voltage of the DC supplies as indicated in **Table 4-6C**.

Table 4-6C. Power Supply Voltages

| Test Point | Supply | Limits |
|------------|--------|-----------------------|
| A1J2-2 | +15 | +15.00 \pm 0.75 Vdc |
| A1J2-3 | -15 | -15.00 \pm 0.75 Vdc |
| A1J12-9 | +5A | 5.00 \pm 0.25 Vdc |

7. Set S2 to the 220 V position and connect the receiver to the AC power supply output.
8. Utilize the digital voltmeter to set the output amplitude of the AC power supply to 264.5 Vac rms.

9. Utilize the digital voltmeter probe to measure and record the voltage of the DC supplies as indicated in **Table 4-6D**.

Table 4-6D. Power Supply Voltages

| Test Point | Supply | Limits |
|------------|--------|------------------|
| A1J2-2 | +15 | +15.00 ±0.75 Vdc |
| A1J2-3 | -15 | -15.00 ±0.75 Vdc |
| A1J12-9 | +5A | 5.00 ±0.25 Vdc |

10. Monitor each of the DC supplies as indicated below with the oscilloscope probe. Decrease the output amplitude of the auto-transformer until spikes appear on the oscilloscope trace. Utilizing the digital voltmeter, measure and record the input voltage to the receiver at this point. The input voltage should be no less than 195.5 Vac rms.

| <u>Test Point</u> | <u>Supply</u> |
|-------------------|---------------|
| A1J2-2 | +15 |
| A1J2-3 | -15 |
| A1J12-9 | +5A |

4.6.2 **RF/IF SECTION, PERFORMANCE TESTS**

4.6.2.1 **IF Amplifier Performance Tests**

- 1) Connect the test equipment as illustrated in **Figure 4-1**.
- 2) Set the receiver to the Standard Test Setting described in **Table 4-5**, except select the AGC off mode and connect the RF millivoltmeter to the SWITCHED IF OUT connector (J8) on the receiver rear panel.
- 3) Adjust the Type 8640B signal generator for a 255.5550 MHz signal, no modulation and set the output to minimum (maximum attenuation). Set the TF-10141 attenuator for a 3 dB loss.
- 4) Increase the signal generator output level to produce a -30 dBm indication on the RF millivoltmeter.
- 5) Set the attenuator to 0 dB and increase the signal generator frequency until the RF millivoltmeter again reads -30 dBm. Note the generator frequency.
- 6) Decrease the signal generator frequency, past 255.5550 MHz, until the millivoltmeter again reaches -30 dBm. Note the generator frequency.

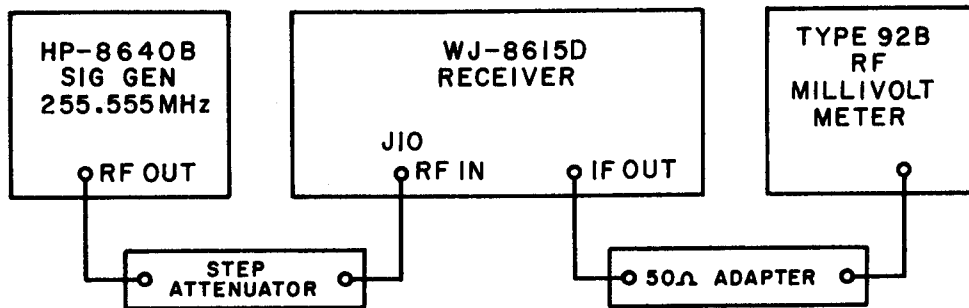

Figure 4-1. IF Amplifier Performance Test, Equipment Connections

- 7) Compute the 3 dB bandwidth by subtracting the frequency reading obtained in **step 4** from the frequency obtained in **step 5**. The computed bandwidth should equal the selected IF bandwidth $\pm 10\%$.
- 8) Set the signal generator frequency for 255.5550 MHz and adjust the output level for -30 dBm reading on the RF millivoltmeter.
- 9) Tune the receiver across the IF passband while observing variations in level above and below the -30 dBm reference. The level variations should be no greater than 2.0 dB peak-to-peak.
- 10) Select bandwidth #2 and repeat **steps 3 through 9**.
- 11) Select bandwidth #3 and repeat **steps 3 through 9**.
- 12) Select bandwidth #4 and repeat **steps 3 through 9**.
- 13) Select bandwidth #5 and repeat **steps 3 through 9**.

4.6.2.2

AM-FM Demodulator Performance Test

- 1) Connect the test equipment as illustrated in **Figure 4-2**.
- 2) Set the receiver to the Standard Test Setting described in **Table 4-5**, except, select FM Detection and the #1 bandwidth.

- 3) Adjust the signal generator for a 255.5550 MHz signal at an output level of -65 dBm. FM modulate the output signal at a 400 kHz rate, with the appropriate peak deviation from **Table 4-7**.
- 4) Connect the Type 332A Distortion Analyzer to the FM MON connector (J4) on the rear panel. Terminate J4 with a 91 ohm load.
- 5) Measure and record the distortion present. This level should be no greater than 5% for all bandwidths.
- 6) Connect the distortion analyzer to the AUDIO OUT connector (J6). Terminate J6 with a 600 ohm load.
- 7) Set the output level and the peak deviation of the signal generator to the levels indicated in **Table 4-7**. Change the deviation rate to 1 kHz for IF bandwidths greater than 20 kHz.
- 8) Ensure the line audio output level is capable of being adjusted to a minimum of 2.45 Vrms.
- 9) Select bandwidth #2 and repeat steps 3 through 8.
- 10) Select bandwidth #3 and repeat steps 3 through 8.
- 11) Select bandwidth #4 and repeat steps 3 through 8.
- 12) Select bandwidth #5 and repeat steps 3 through 8.

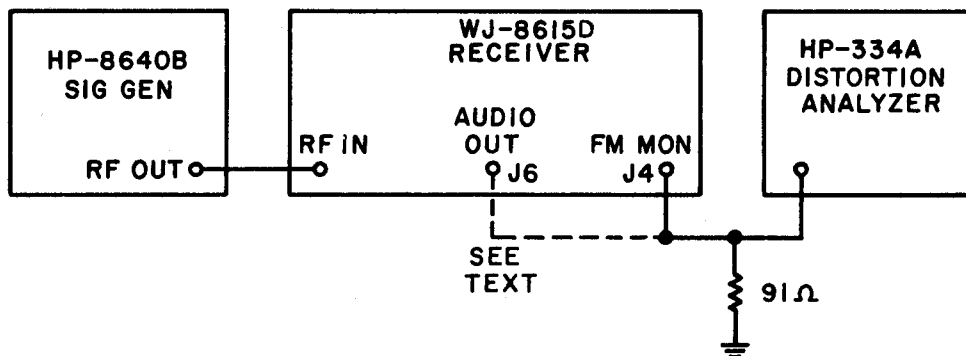

Figure 4-2. AM-FM Demodulator Performance Test, Equipment Connections

4.6.2.2.1 FM Monitor Output

- 1) Connect the test equipment as illustrated in **Figure 4-2**.
- 2) Set the receiver to the Standard Test Setting described in **Table 4-5**.
- 3) On the receiver, set the FM detection mode.
- 4) Set the output level and peak deviation of the signal generator in accordance with **Table 4-7**.
- 5) Measure and record the output level present at the FM MON output connector (J4). This level should be from 0.63 to 1.25 Vrms. Terminate J4 with a 91 ohm load.

4.6.2.3 AGC Performance Test

- 1) Set the receiver to the Standard Test Setting described in **Table 4-5**, except select bandwidth #1.
- 2) Adjust the signal generator to AM modulate at 50% and adjust its output to the levels specified in **Table 4-7**.

Table 4-7. Input Conditions for Sensitivity Conditions

| Bandwidth (kHz) | Input Level (dBm) | 30% Deviation (kHz) | Noise Floor (dBm) |
|-----------------|-------------------|---------------------|-------------------|
| 6.4 | -109 | 1.9 | -128 |
| 10 | -107 | 3 | -126 |
| 20 | -104 | 6 | -123 |
| 50 | -100 | 15 | -119 |
| 75 | -98 | 22.5 | -117 |
| 100 | -97 | 30 | -116 |
| 300 | -92 | 90 | -111 |
| 500 | -90 | 150 | -109 |
| 1000 | -87 | 300 | -107 |
| 2000 | -84 | 600 | -103 |
| 4000 | -81 | 1200 | -100 |

- 3) Connect the RF millivoltmeter to the SW IF connector (J8).
- 4) Adjust the Line Audio output amplitude for an output level of 1.94 Vrms (-2 dB). Note the IF output amplitude on the RF millivoltmeter.
- 5) Increase the output level of the signal generator to -8.5 dB.

- 6) Calculate and record the change in audio output amplitude from the result in **step 4**. This change should be no greater than 6 dB.
- 7) Calculate and record the change in IF output amplitude from the result in **step 4**. This change should be no greater than 12 dB.
- 8) If the receiver is equipped with the FE-2 option, repeat **steps 4 through 6** except tune the receiver and the signal generator to 501 MHz. Maximum input level in UHF is -13.5 dBm.

4.6.2.3.1 Pulse Operation

- 1) Connect the test equipment as illustrated in **Figure 4-3**.

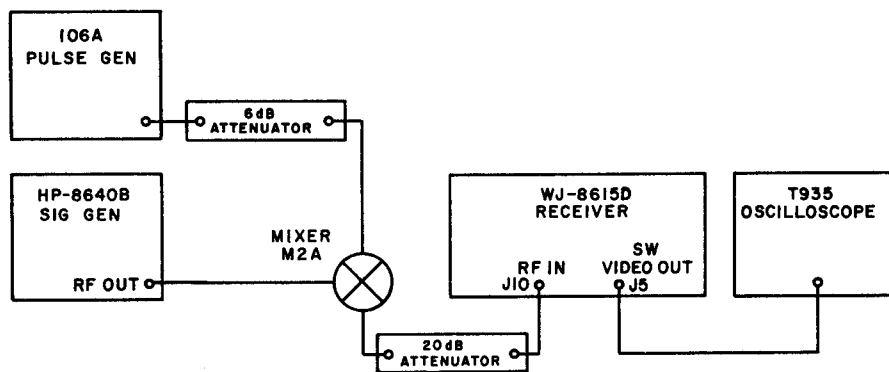

Figure 4-3. Pulse Operation Performance Test, Equipment Interconnections

- 2) Select the Pulse Detection mode on the receiver and connect the oscilloscope to the SW VIDEO OUT connector (J5). Select a bandwidth of 1 MHz or greater.
- 3) Set the Type 106A Pulse Generator output level to 5.0 V peak with a pulse width and repetition rate as determined from **Table 4-8**.

Table 4-8. Pulse AGC Test Conditions

| Bandwidth (kHz) | Pulse Width | Repetition Rate (kHz) | RF Generator Level (dBm) |
|-----------------|--------------|-----------------------|--------------------------|
| 1000 | 1 μ s | 100 Hz | -77 |
| 2000 | 0.5 μ s | 100 Hz | -74 |
| 4000 | 0.25 μ s | 100 Hz | -71 |

- 4) Set the RF generator output level as determined in **Table 4-8**.

NOTE

Insertion loss of the mixer is typically 7 dB,
nominal.

- 5) Note the amplitude of the video output as displayed on the oscilloscope.
- 6) Increase the output level of the RF generator to -5 dBm.
- 7) Note the amplitude of the video output pulse as displayed on the oscilloscope. This level should be no greater than twice the amplitude noted in **step 5** (equivalent to a 6 dB change).

4.6.2.4

Audio/Video Performance Test

- 1) Connect the test equipment as illustrated in **Figure 4-4**.

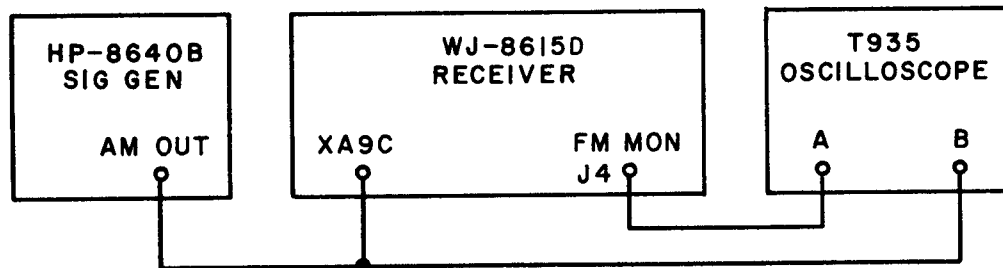

Figure 4-4. Audio/Video Performance Test, Equipment Connections

- 2) Remove AM/FM Demodulator subassembly (A1A9). Set the receiver to FM Detection and select the #1 bandwidth.
- 3) Connect the audio signal generator to pin 4 of connector XA9C and to channel B of the oscilloscope. Adjust the generator to produce a 1 kHz signal at 2 V peak-to-peak amplitude as observed on channel B of the oscilloscope. Remove the oscilloscope probe.

- 4) Connect the channel A input of the oscilloscope, and a 93Ω termination to J4 (FM MON) on the receiver rear panel. Observe that the signal level at J4 is between 2 and 3 V peak-to-peak.
- 5) Move the channel A input of the oscilloscope and the 93Ω termination to J5 (SEL VID) on the receiver rear panel. Observe that no AM signal is present.
- 6) Select AM detection mode. Move the input signal from the signal generator to pin 5 of connector XA9A. Observe a signal of from .8 to 1.5 V peak-to-peak displayed on the A trace of the oscilloscope.
- 7) Connect the channel B input of the oscilloscope and a 600Ω termination to the J6 or J7 (AUDIO) outputs on the receiver rear panel.
- 8) Operate the LINE ADJ control (R1) on the rear panel to the point just before clipping of the audio signal peaks as observed on the oscilloscope. The amplitude should be no less than 7.0 V peak-to-peak.
- 9) Set the output level of the signal generator to -60 dBm and set the LINE ADJ control for 2.45 Vrms as indicated by the distortion analyzer voltmeter. The distortion should be no greater than 5%.
- 10) Replace the AM/FM Demodulator subassembly (A1A9). Set the controls of the signal generator for variable, internal and AM modulation. Connect the generator output to the RF input of the receiver (J10). Adjust the generator for 30% modulation at a 1.0 kHz rate. set the LINE ADJ control for a reference on the dB scale of the distortion analyzer at or near the 2.45 Vrms point. Note the reference level.
- 11) Vary the modulation frequency of the signal generator from 50 Hz to 15 kHz noting the greatest differences from the reference. Measure the greatest positive difference from the reference. Measure the greatest negative difference from the reference. Add the results. The sum should be no greater than 2.0 dB.
- 12) Connect the distortion analyzer, set for voltmeter operation, to the SEL VID connector (J5). Set the signal generator as specified in **Table 4-8** for the selected bandwidth. AM modulate the signal generator 50% at a 1 kHz rate (400 Hz rate for bandwidths 20 kHz).
- 13) Measure the AM video output level present on the distortion analyzer. This level should be 0.21 to 0.59 Vrms.
- 14) Select the FM detection mode and adjust the signal generator as in step 12 except FM modulate at a peak deviation of 30% of the selected IF bandwidth. The FM video output level present on the distortion analyzer should be 0.21 to 0.59 Vrms.

4.6.2.5 Preamplifier/Converter Performance Test

- 1) Connect the test equipment as illustrated in Figure 4-5.

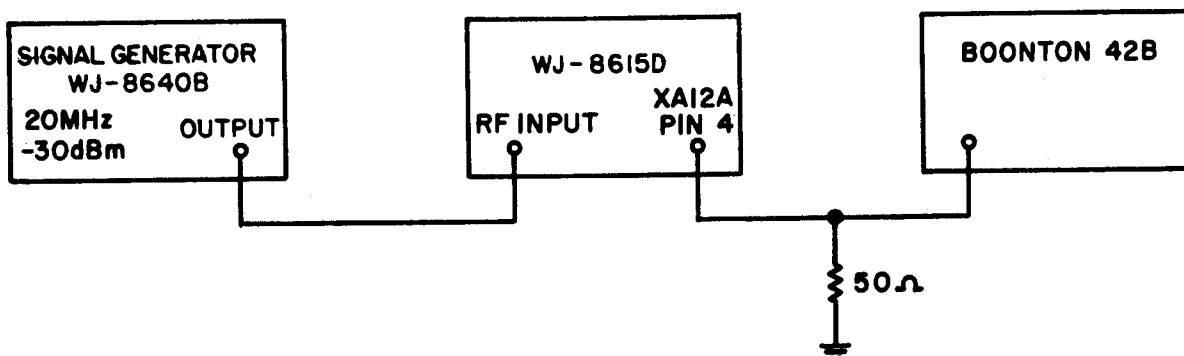

Figure 4-5. Preamplifier/Converter Performance Test, Equipment Connections

- 2) Set the receiver to 20.0000 MHz, IF bandwidth #1, AGC OFF and AFC OFF.
- 3) Set the RF generator for 20 MHz at -30 dBm and apply signal to J10.
- 4) Remove the IF Filter/Amplifier subassembly (A1A12).
- 5) Connect RF cable to connector XA12A, pin 4 and measure the level with the RF millivoltmeter with a 50 ohm termination. Gain through the module should be 18 dB \pm 1.5 dB.
- 6) If the IF gain is less than 16.5 dB, refer to the module alignment procedure, **paragraph 4.7.1.1** to isolate the faulty stage.

4.6.3 DIGITAL CONTROL SECTION, PERFORMANCE TESTS

4.6.3.1 Microprocessor Power Tests

- 1) Set the oscilloscope for a DC coupled input with the horizontal sweep set to 0.5 μ sec/Div.
- 2) Connect the oscilloscope to the XA3 connector pins listed in **Table 4-9** and observe the results as described in the table.

Table 4-9. Microprocessor Control Signals

| Connector Pin | Description | Indication |
|---------------|---------------------------|----------------------|
| P1-3 | $\overline{\text{FIRQ}}$ | Changing logic level |
| P1-4 | $\overline{\text{IRQ}}$ | Changing logic level |
| P2-4 | $\overline{\text{E}}$ | Changing logic level |
| P2-6 | $\overline{\text{E}}$ | Changing logic level |
| P2-7 | $\overline{\text{G R/W}}$ | Changing logic level |
| P2-3 | $\overline{\text{R/W}}$ | Changing logic level |
| P2-8 | $\overline{\text{R/W}}$ | Changing logic level |
| P2-5 | $\overline{\text{PFAIL}}$ | Constant logic "1" |
| P2-14 | BATT OUT | 2.8 Vdc |
| P2-50 | +5 V | +5 Vdc |

Logic "1" = +2.7 V

Logic "0" = 0 V

- 3) To verify the operation of the microprocessor power monitor circuit, connect CH1 of the oscilloscope to U7 pin 7 (+5 V) of the microprocessor (A1A3). Trigger to CH1 NORM+. Connect CH2 to A1A3 TP22 ($\overline{\text{PFAIL}}$), set the oscilloscope to 2 V/Div and 2 msec/Div.
- 4) Apply power to the receiver. Verify that $\overline{\text{PFAIL}}$ (CH2) does not go high until at least 1 msec. after +5 V (CH1 stabilizes).
- 5) Remove power from receiver. Verify that CH1 (+5 V) is still at least 4.5 V when the trigger occurs. Trigger to CH2 NORM-.
- 6) If any of these test fail, it indicates improper power monitor circuit operation. This circuit must function in order to perform the following Digital Control Section diagnostic tests.

4.6.3.2 Static Microprocessor Diagnostic Tests

The following test verify the basic operation of the microprocessor, I/O decoders, system software and the diagnostic software. Signature analysis is utilized to verify the results of most of these tests. The data lines of the microprocessor are separated from the bus by a

diagnostic header forcing the data lines to a "NOP" instruction. This causes the microprocessor to function like a 16-bit binary counter. All possible combinations of the 16 address lines are presented allowing all input decoders to be verified for proper operation. This also allows data from the EPROMS to be placed on the data bus for verification. These tests should be performed in the order presented because each test depends on the verification of the components of the preceding tests.

4.6.3.2.1 Microprocessor Test

- 1) This test should be run with all cards installed in the Digital Control Section of the receiver.
- 2) Remove the jumper pack from the U2 slot and install the diagnostic header into the U2 socket.
- 3) Connect and adjust the HP-5004A Signature Analyzer as indicated in **Table 4-10**.
- 4) Perform the signature analysis on the first entry (+5 Vdc) in **Table 4-10** to verify setup. A failure indicates improper hook-up, a shorted start/stop signal, or improper setup of the signature analyzer.
- 5) If everything in **step 4** has been checked and the +5 Vdc signature still does not correspond to that specified in the table, replace the microprocessor and test again.
- 6) Verify the remaining signatures in **Table 4-10**.
- 7) A fault indicates:
 - an open or shorted address line
 - a defective microprocessor

Table 4-10. Microprocessor Tests

| Signature Analyzer Setting and Connection | | | |
|---|---------------------------------------|---------------------------------------|-----------|
| START | STOP | CLOCK | |
| Trailing A1A3 (TP8) Edge U7 pin 23 | Trailing A1A3 (TP8) Edge U7 pin 23 | Trailing A1A3 (TP2) Edge U7 pin 34 | |
| Test Number | Signature Name | Test Point | Signature |
| 1 | +5 | A1A3 U3 pin 1 | 0003 |
| 2 | A0 | U13 pin 2 | UUUU |
| 3 | A1 | U13 pin 17 | FFFF |
| 4 | A2 | U13 pin 4 | 8484 |

Table 4-10. Microprocessor Tests (Cont'd)

| Test Number | Signature Name | Test Point | Signature |
|-------------|--------------------|-----------------|-----------|
| 5 | A3 | U13 pin 15 | P763 |
| 6 | A4 | P1 pin 17 | 1U5P |
| 7 | Z5 | U13 pin 6 | 0356 |
| 8 | A6 | U13 pin 13 | U759 |
| 9 | A7 | U13 pin 8 | 6F9A |
| 10 | A8 | U13 pin 11 | 7791 |
| 11 | A10 | U8 pin 3 | 37C5 |
| 12 | A9 | U8 pin 2 | 6321 |
| 13 | A11 | U8 pin 14 | 6U28 |
| 14 | A12 | U8 pin 13 | 4FCA |
| 15 | A13 | U1 pin 15 | 4868 |
| 16 | A14 | U1 pin 14 | 9UP1 |
| 17 | | U3 pin 20 | 1183 |
| 18 | | U4 pin 20 | 64HF |
| 19 | | U8 pin 15 | C9U1 |
| 20 | | U10 pin 5 | 7074 |
| 21 | | U10 pin 11 | PF63 |
| 22 | (TP10) | U8 pin 10 | ZF1U |
| 23 | | U8 pin 1 | 09UA |
| 24 | $\overline{I/O 1}$ | P1 pin 33 | 3H82 |
| 25 | $\overline{I/O 2}$ | P1 pin 34 | 796P |
| 26 | $\overline{I/O 3}$ | P1 pin 35 | U5F0 |
| 27 | $\overline{I/O 4}$ | P1 pin 36 | C8H5 |
| 28 | | U12 pin 4 | 7-77 |
| 29 | | U12 pin 9 | PF60 |
| 30 | | U6 pin 18 | 7074 |
| 31 | | U5 pin 18 | PF63 |
| 32 | BAO | P1 pin 9 | U4F8 |
| 33 | BA1 | P1 pin 11 | 6U0A |
| 34 | BA2 | P1 pin 13 | H228 |
| 35 | BA3 | P1 pin 15 | 7951 |
| 36 | BA4 | P1 pin 17 | 1U5P |
| 37 | BA5 | P1 pin 19 | 579P |
| 38 | BA6 | P1 pin 21 | 72A8 |
| 39 | BA7 | P1 pin 23 | 9U12 |
| 40 | BA8 | P1 pin 25 | 3289 |
| 41 | (R1800) | A1A2 U15 pin 1 | 3113 |
| 42 | (R1880) | U8 pin 1 | H96P |
| 43 | (R1900) | U9 pin 1 | U5A0 |
| 44 | (R1980) | U8 pin 15 | 247H |
| 45 | (19C0-19FF) | U13 pin 3 | U699 |
| 46 | (ASE) | U10 pin 1 | F9CU |
| 47 | \overline{RAD} | A1A4 U15 pin 21 | U5F3 |
| 48 | | A1A5 U9 pin 1 | 796P |
| 49 | | U9 pin 11 | 796H |
| 50 | | A1A4 U17 pin 5 | U5F3 |

4.6.3.2.2 Address Bus Test

- 1) Perform steps 1 through 6 of paragraph 4.6.3.2.1 utilizing Table 4-10.
- 2) A fault indicates:
 - an open or shorted address line
 - a defective source. It is suggested that signatures be verified at the 1C before replacing the IC's.

Table 4-11. Address Bus Test

Signature Analyzer Setting and Connection

| START | STOP | CLOCK | |
|---|---------------------------------------|---------------------------------------|-----------|
| Trailing A1A3 (TP8) Edge U7 pin 23 | Trailing A1A3 (TP8) Edge U7 pin 23 | Trailing A1A3 (TP2) Edge U7 pin 34 | |
| NOTE: Momentarily short TP3 to ground. | | | |
| Test Number | Signature Name | Test Point | Signature |
| 1 | +5 | A1A2 U5 pin 1 | 0003 |
| 2 | (W1800) | U16 pin 9 | 3113 |
| 3 | <u>WFP</u> | P1 pin 22 | H96P |
| 4 | | U11 pin 4 | U5A0 |
| 5 | (W1900) | U4 pin 1 | C930 |
| 6 | (W1902) | U2 pin 1 | 6C90 |
| 7 | <u>2nd PLS</u> | P1 pin 16 | HAP7 |
| 8 | (W1904) | U2 pin 13 | 76CA |
| 9 | (W1905) | U4 pin 13 | 1HAH |
| 10 | <u>3rd PLS</u> | P1 pin 14 | 8768 |
| 11 | <u>CTR ST</u> | P1 pin 12 | A1H9 |
| 12 | (W1C00) | A1A4 U10 pin 16 | 6AC0 |
| 13 | (A1C40) | U11 pin 16 | U804 |
| 14 | (W1C80) | U12 pin 16 | 2UPC |
| 15 | (W1CC0) | U13 pin 1 | 953C |
| 16 | (W1D00) | U9 pin 11 | 617C |
| 17 | (W1D40) | U16 pin 1 | 0965 |
| 18 | | U15 pin 32 | 0966 |
| 19 | (W1D80) | U14 pin 11 | 1F55 |
| 20 | (W1A00) | A1A5 U14 pin 11 | H9H1 |
| 21 | | U13 pin 11 | 7AC2 |
| 22 | | U12 pin 11 | 9671 |
| 23 | | P2 pin 14 | 2FF0 |
| 24 | | U4 pin 11 | H2A8 |
| 25 | | U8 pin 11 | H2A8 |
| 26 | | U7 pin 11 | A0U4 |
| 27 | | U6 pin 11 | F568 |

4.6.3.2.3 **Front Panel Keyboard Test**

- 1) This test is an imbedded routine contained in firmware. To start routine, momentarily ground A1A3 TP5.
- 2) Receiver front panel display indicates: S1G - An A. --
- 3) At this time any front panel key may be depressed and the key code for that key is indicated. The display indicates: CODE ---X. Refer to **Table 4-12** for the key codes.

Table 4-12. Front Panel Key Codes

| Key | Key Code | Key | Key Code |
|------------|----------|-----------|----------|
| Det Mode | 0 | BFO | 9 |
| BW Select | 4 | AFC | d |
| RF/IF Gain | 8 | Tune Lock | 5 |
| Change | A | Faster | 2 |
| Change | E | Slower | 6 |
| COR Level | C | Control | 1 |

- 4) To exit this test, remove power from the receiver.

4.6.3.2.4 **Digital-to-Analog Ramp Tests**

- 1) Utilize an oscilloscope to confirm the correct signals are present. Connect CH1 to A1A5 TP11.
- 2) DC couple Trigger to CH1, TRIG NORM, - slope.
- 3) Utilize CH2 to probe indicated tests points on the Analog/Digital subassembly A1A5. Refer to **Table 4-13**.
- 4) Unless specified otherwise, ramps are positive going from 0 to approximately +13 Vdc at approximately 4 V/msec.

Table 4-13. Digital-to-Analog Ramps

| Test Point | Nomenclature | Ramp |
|------------|--------------------|---|
| P2 pin 14 | IF NORM | 1.5 msec. after trigger |
| P2 pin 16 | IF AGC | 5.4 msec. after trigger |
| P2 pin 18 | DET AGC | 9.0 msec. |
| P2 pin 20 | BFO TV | 13 msec. |
| P2 pin 22 | VHF AGC | 17 msec. |
| P2 pin 24 | UHF AGC | 21 msec. |
| P2 pin 26 | 2nd LO COARSE TUNE | 25 msec. after trigger (at .33 V/msec. slope) |

4.6.3.2.5 Control Line Tests

- 1) Perform steps 1 through 6 of paragraph 4.6.3.2.1 utilizing Table 4-14.
- 2) A fault indicates:
 - an open or shorted address line
 - a defective source.

Table 4-14. Control Line Test

Signature Analyzer Setting and Connection

| START | | STOP | | CLOCK | |
|--|-----------------------------|---|-----------|--|--|
| Leading A1A5 (TP11) Edge U14 pin 12 | | Trailing A1A5 (TP11) Edge U14 pin 12 | | Trailing A1A3 (TP10) Edge U8 pin 10 | |
| Test Number | Signature Name | Test Point | Signature | | |
| 1 | +5 | A1A5 U2 pin 16 | 4802 | | |
| 2 | 2nd LO D0 | P2 pin 25 | 7F8P | | |
| 3 | 2nd LO D1 | P2 pin 26 | HA7A | | |
| 4 | 2nd LO D2 | P2 pin 27 | F418 | | |
| 5 | 2nd LO D3 | P2 pin 28 | H154 | | |
| 6 | 2nd LO A0 | P2 pin 29 | pC4A | | |
| 7 | 2nd LO A1 | P2 pin 30 | 6F25 | | |
| 8 | 2nd LO A1 | P2 pin 31 | 04P8 | | |
| 9 | Fine on/off | P2 pin 32 | 38HC | | |
| 10 | SP1 | P2 pin 33 | 26HP | | |
| 11 | SP2 | P2 pin 34 | P24A | | |
| 12 | $7/\bar{2}$ | P2 pin 35 | FA17 | | |
| 13 | SP3 | P2 pin 36 | | | |
| 14 | 1 ¹ | P2 pin 37 | 4C8C | | |
| 15 | 1 ² | P2 pin 38 | 88H6 | | |
| 16 | 1 ⁴ | P2 pin 39 | 9U3A | | |
| 17 | 1 ⁸ | P2 pin 40 | A495 | | |
| 18 | 2 ¹ | P2 pin 41 | 96PF | | |
| 19 | 2 ² | P2 pin 42 | 725C | | |
| 20 | 2 ⁴ | P2 pin 43 | P5PH | | |
| 21 | 2 ⁸ | P2 pin 44 | 5CP0 | | |
| 22 | $\overline{\text{FLOAD}}$ | P2 pin 45 | 4802 | | |
| 23 | U ¹ | P2 pin 46 | 85PA | | |
| 24 | U ² | P2 pin 47 | 77F7 | | |
| 25 | $\overline{\text{UHF/VHF}}$ | P2 pin 48 | 6PCP | | |
| 26 | $\overline{\text{FWAM}}$ | P1 pin 3 | 8977 | | |
| 27 | CW | P1 pin 4 | 872H | | |
| 28 | CW + SSB | P1 pin 5 | 2C0P | | |
| 29 | $\overline{\text{USB/LSB}}$ | P1 pin 6 | 57FF | | |

Table 4-14. Control Line Test (Cont'd)

| Test Number | Signature Name | Test Point | Signature |
|-------------|----------------|-----------------|-----------|
| 30 | 1SB | P1 pin 7 | HF8C |
| 31 | SQUELCH | P1 pin 8 | 8589 |
| 32 | PRESEL ATTN | P1 pin 9 | HA0F |
| 33 | AM PK DMP | P1 pin 10 | A4H5 |
| 34 | PRESEL D0 | P1 pin 11 | CA49 |
| 35 | PRESEL D1 | P1 pin 13 | 9638 |
| 36 | PRESEL D2 | P1 pin 14 | 84A7 |
| 37 | PRESEL D3 | P1 pin 15 | 2AP4 |
| 38 | PRESEL D4 | P1 pin 16 | 2F06 |
| 39 | PRESEL D5 | P1 pin 17 | CU26 |
| 40 | PRESEL D6 | P1 pin 18 | 5642 |
| 41 | PRESEL D7 | P1 pin 19 | HFH3 |
| 42 | PRESEL D8 | P1 pin 20 | A6PA |
| 43 | PRESEL D9 | P1 pin 22 | 2659 |
| 44 | PRE CODE 0 | P1 pin 24 | 4A12 |
| 45 | PRE CODE 1 | P1 pin 26 | F823 |
| 46 | PRE CODE 2 | P1 pin 27 | 3UU7 |
| 47 | PRE STB | P1 pin 28 | P432 |
| 48 | PRINTER | U10 pin 3 | 4F6F |
| 49 | SERIAL OUT | U10 pin 2 | 1FU5 |
| 50 | | A1A4 U8 pin 3 | P3A6 |
| 51 | | U8 pin 5 | 5P9H |
| 52 | | U8 pin 7 | 462F |
| 53 | | U8 pin 9 | 8FA9 |
| 54 | | U8 pin 11 | AU23 |
| 55 | | U8 pin 14 | PF38 |
| 56 | | U9 pin 16 | HA99 |
| 57 | | U9 pin 19 | H5FC |
| 58 | SPR DRV | P1 pin 29 | 929C |
| 59 | COR EXT | P1 pin 31 | 9HF9 |
| 60 | SPR4 | P2 pin 28 | 8P2P |
| 61 | SPR5 | P2 pin 30 | 85P5 |
| 62 | SPR6 | P2 pin 32 | 8134 |
| 63 | SPR7 | P2 pin 34 | C321 |
| 64 | SPR8 | P2 pin 35 | F477 |
| 65 | FM NAR/MID | P2 pin 36 | 426C |
| 66 | FM WIDE | P2 pin 37 | 952H |
| 67 | SPR9 | P2 pin 38 | 569P |
| 68 | | A1A2 U14 pin 12 | 1HHA |
| 69 | | U14 pin 10 | 0L49 |
| 70 | | U14 pin 4 | 5717 |
| 71 | | U14 pin 2 | 3610 |
| 72 | | U5 pin 4 | 2016 |
| 73 | | U4 pin 12 | 1776 |

4.6.3.3 Dynamic Microprocessor Test

The following test should be run only after all of the static tests in **paragraph 4.6.3.2** have been completed and the proper operation of all boards and software has been verified. The dynamic test checks the standard non-interrupt functions of the Digital Control Section.

4.6.3.3.1 Buffered Data Lines

- 1) This test will test the buffered data lines. Install signature header in A1A3U2.
- 2) Apply power to receiver.
- 3) Momentarily ground A1A3 TP5.
- 4) Refer to **Table 4-15** for signature analysis.

Table 4-15. Buffered Data Line Test

Signature Analyzer Setting and Connection

| START | | STOP | | CLOCK | |
|--|----------------|---|--|-------------------------------|--|
| Leading A1A5 (TP11) Edge U14 pin 12 | | Trailing A1A5 (TP11) Edge U14 pin 12 | | Leading A1A3 Edge U8 pin 9 | |
| Test Number | Signature Name | Test Point | | Signature | |
| 1 | +5 | U15 pin 24 | | 446P | |
| 2 | DIO 0 | P2 pin 9 | | 850A | |
| 3 | DIO 1 | P2 pin 11 | | 7445 | |
| 4 | DIO 2 | P2 pin 13 | | F8P5 | |
| 5 | DIO 3 | P2 pin 15 | | PF9U | |
| 6 | DIO 4 | P2 pin 17 | | C583 | |
| 7 | DIO 5 | P2 pin 19 | | 1F5F | |
| 8 | DIO 6 | P2 pin 21 | | 649U | |
| 9 | DIO 7 | P2 pin 23 | | 53AF | |

4.6.4 **SYNTHESIZER SECTION PERFORMANCE TESTS**

4.6.4.1 Reference Generator, Performance Tests

- 1) Connect the frequency counter first to connector pin 17 of P2, then to connector pin 13. Observe that the frequency present at both connector pins is 250 kHz.
- 2) Connect the frequency counter to connector pin 13 of P1 and observe the frequency present. This frequency should be 32.1 MHz.

- 3) Remove the frequency counter and observe the waveform present at connector pins 17 and 13 of P2 and pin 13 of P1. The waveform present at each connector pin should be a symmetrical square wave switching between 0 and approximately +4 V.

4.6.4.2 1st LO Synthesizer, Performance Tests

- 1) Connect the frequency counter to the 1st LO Synthesizer output jack A2J1.
- 2) Utilizing the oscilloscope, verify the presence of the 250 kHz reference, from the reference generator, at connector pin 15 of P1.
- 3) Tune the receiver to the frequencies listed in **Table 4-16** and observe the 1st LO frequency varies as listed in the table.
- 4) If the results are not as listed in **Table 4-16**, utilize the oscilloscope to verify the BCD control words provided at the indicated P1 connector pins.

Table 4-16. 1st LO Synthesizer Frequency vs. Tuned Frequency

| Tuned Freq. (MHz) | 1st LO Freq. (MHz) (A2J1) | Control Logic Input 100 MHz | | | | (A1A7P1) 10 MHz | | | | 7/12 | | |
|----------------------|------------------------------|--------------------------------|---|----|---|--------------------|-----|----|----|------|----|----|
| | | Bit | 8 | 4 | 2 | 1 | Bit | 8 | 4 | | 2 | 1 |
| 20.0000 | 577.55 | | 0 | 1 | 0 | 1 | | 0 | 1 | 1 | 1 | 1 |
| 25.0000 | 582.55 | | 0 | 1 | 0 | 1 | | 1 | 0 | 0 | 0 | 0 |
| 50.0000 | 607.55 | | 0 | 1 | 1 | 0 | | 0 | 0 | 0 | 0 | 1 |
| 250.0000 | 807.55 | | 1 | 0 | 0 | 0 | | 0 | 0 | 0 | 0 | 1 |
| 336.0000 | 892.55 | | 1 | 0 | 0 | 0 | | 1 | 0 | 0 | 1 | 0 |
| 499.0000 | 1052.55 | | 0 | 0 | 0 | 0 | | 0 | 1 | 0 | 1 | 0 |
| | XA7A pins: | | 7 | 12 | 5 | 22 | | 24 | 20 | 18 | 16 | 19 |

- 5) Remove the frequency counter from A2J1 and connect the RF millivoltmeter and a 50 ohm load. Observe the output level is at least +3 dBm.
- 6) Tune the receiver through the 20-500 MHz frequency range while observing the output level on the RF millivoltmeter. Observe the output level of at least +3 dBm is present throughout the frequency range of the 1st LO.

4.6.4.3 2nd LO Synthesizer, Performance Tests

- 1) Connect the frequency counter to the 2nd LO output jack A1A6J1. Observe the frequency present is between 531.16 to 536.16 MHz.
- 2) Remove the frequency counter from A1A6J1 and connect the RF millivoltmeter and a 50 ohm load. Observe the output level is approximately +2 dBm.
- 3) Tune the receiver through the 20-25 MHz frequency range tuning in 10 kHz steps while observing the output level on the RF millivoltmeter. Observe the output level of at least +3 dBm is present throughout the frequency range of the 2nd LO.
- 4) Verify the presence of +5 V at connector pins 4 and 31 of P1.

4.7 ALIGNMENT PROCEDURES

The following alignment procedures should not be performed on a routine basis. These alignment procedures should be performed after repairs have been completed or as a touch-up after a subassembly has been replaced. Only after it has been determined that alignment is necessary, should any adjustment be made. **Table 4-17** lists the WJ-8615D standard unit settings to be utilized during the alignment procedures.

The typical signal waveforms illustrated in the following alignment procedures are reproductions of actual waveform responses. Due to the variables involved with alignment, the equipment utilized, equipment settings, and component interaction, the waveforms should be used as alignment aids rather than waveform models. Oscilloscope voltage settings (V/DIV) will vary depending on the test equipment utilized.

Table 4-17. Standard Alignment Settings

| Parameter | Setting |
|------------------|-----------------------|
| CONTROL | LCL |
| FREQUENCY MHz | 100.0000 |
| TUNING RATE | Digit Flashing 100 Hz |
| BFO | OFF |
| AFC | OFF |
| COR LEVEL | 00 |
| RF/IF GAIN | MAXIMUM |
| BANDWIDTH SELECT | 300 kHz (or less) |
| DETECTION MODE | AM |
| GAIN CONTROL | MGC |

4.7.1 RF/IF SECTION ALIGNMENT PROCEDURE

4.7.1.1 Preamplifier/Converter (A1A13), Alignment

- 1) Extend the Preamplifier/Converter module via test cable TC30047 and connect the test equipment as illustrated in **Figure 4-6**. Refer to **Figure 5-27** and **Figure 5-29** for jumper (JP) locations.

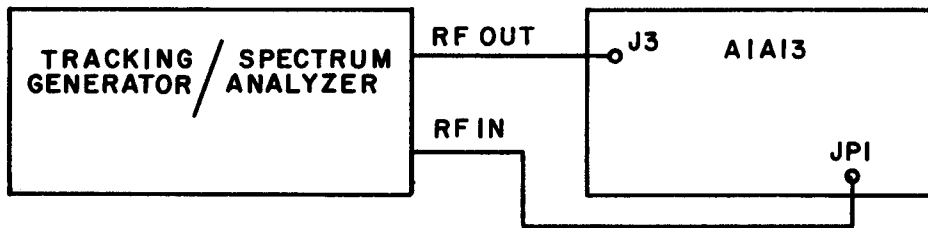

Figure 4-6. Low-pass Filter Alignment, Equipment Connections

- 2) Adjust C15, C16, C17 and C18 to produce the response illustrated in **Figure 4-7**. Note the frequency and the component adjustment for each point. The Pre-Amp LPF filter response should be flat from 20-500 MHz and have 12-14 dB of gain.

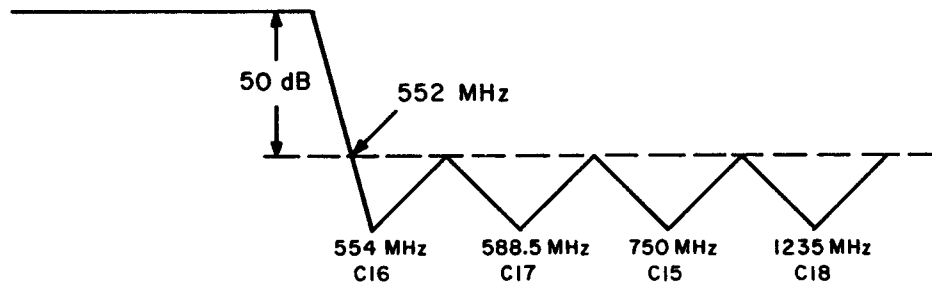

Figure 4-7. Low-pass Filter Notch Adjustments

With the spectrum analyzer settings set as listed below, **Figure 4-8** represents a typical Low-pass Filter Response.

Spectrum Analyzer Settings

| | |
|------------------|--------------|
| Center Frequency | 570 MHz |
| Bandwidth | 300 kHz |
| Scan Per Div | 0 - 1250 MHz |
| Input Atten | 20 dB |
| Scan Time | 5 msec |
| Log Ref | 10 dB Log 10 |

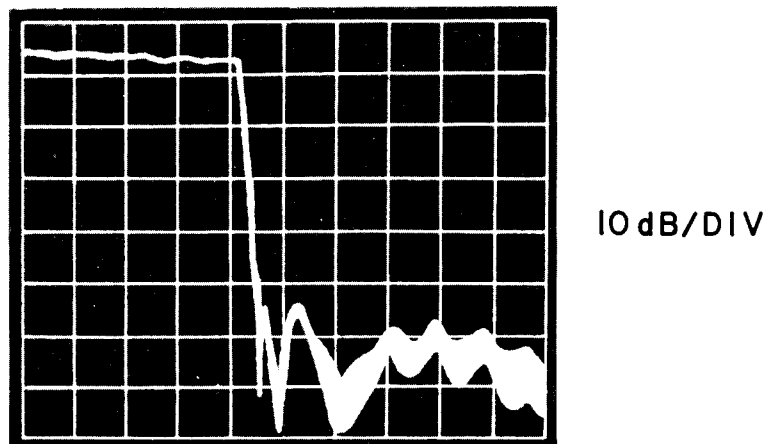

Figure 4-8. Low-pass Filter Response

- 3) Remove (A1A13) A1JP1 and insert a jumper connector at (A1A13) A1JP1 and another jumper connector at (A1A13) A2JP1.
- 4) Calibrate the Wiltron for a 0 dBm reference on the center trace of the display with the following Wiltron settings:

| T50 | G50 |
|-----------|---------------------------|
| 10 dB/div | Marker 5 MHz |
| | Sweep Width 5 MHz |
| | Center Freq. 555 MHz |
| | Sweep Rate Fast |
| | Trigger Auto |
| | RF -20 dB |

- 5) Connect the equipment as illustrated in **Figure 4-9** and adjust the Offset on the Wiltron to verify the gain. (Change the T50 dB/div to 1 dB/div provide greater accuracy.)

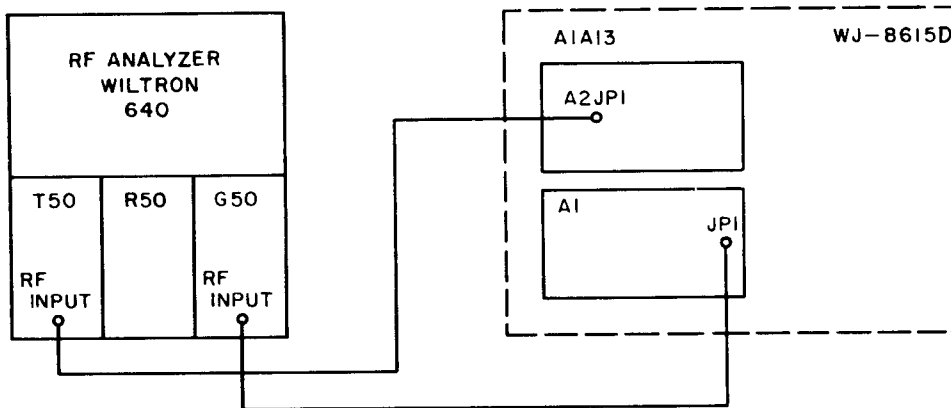

Figure 4-9. 1st Converter Alignment, Equipment Connections

- Adjust C3, C4, C5, C6, C7, C8 and C9 to produce the best symmetrical response at 555 MHz having between 8.5 and 9 dB of gain and a 3 dB bandwidth of between 15 and 17 MHz. **Figure 4-10** illustrates a typical First Converter Signal Response.

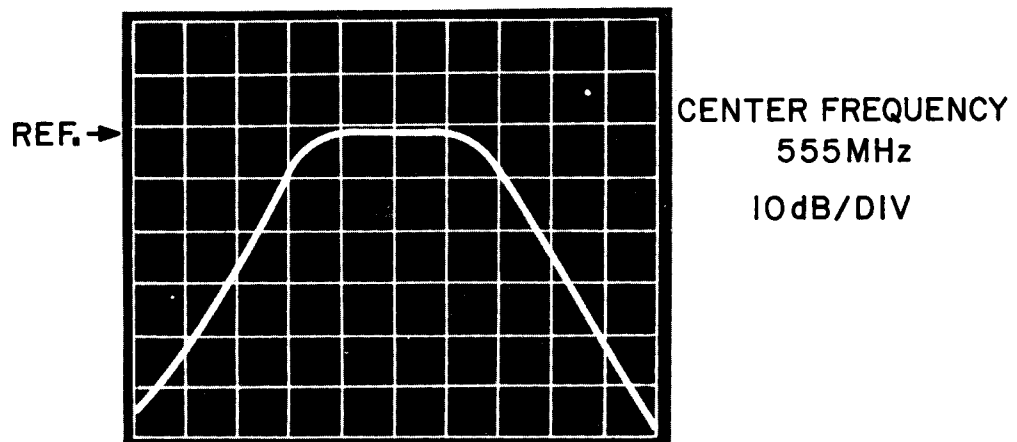

Figure 4-10. First Converter Typical Response

- 7) Connect the test equipment as illustrated in **Figure 4-11**.

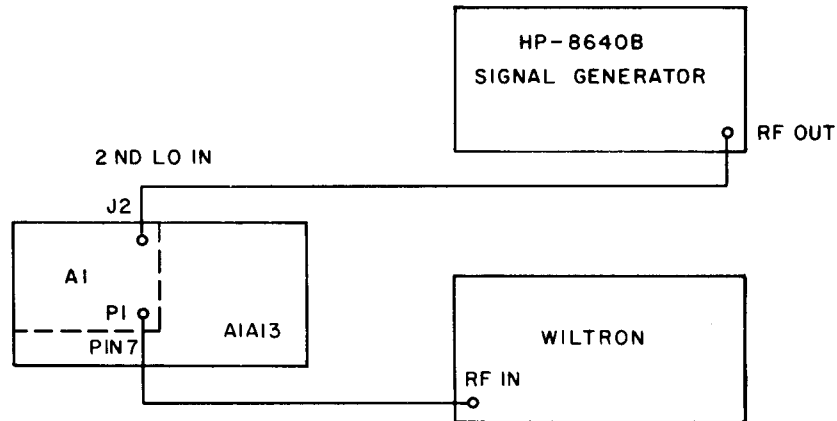

Figure 4-11. Second Converter Alignment, Equipment Connections

- 8) Set the signal generator to 533.6 MHz, CW, at an output level of +3 dBm and center the Wiltron display frequency at 555 MHz.
- 9) Adjust A2 L3, L4 and L5 to produce a flat response, 6 MHz wide at the 1 dB bandwidth, and having 6 dB gain as illustrated in **Figure 4-12**.

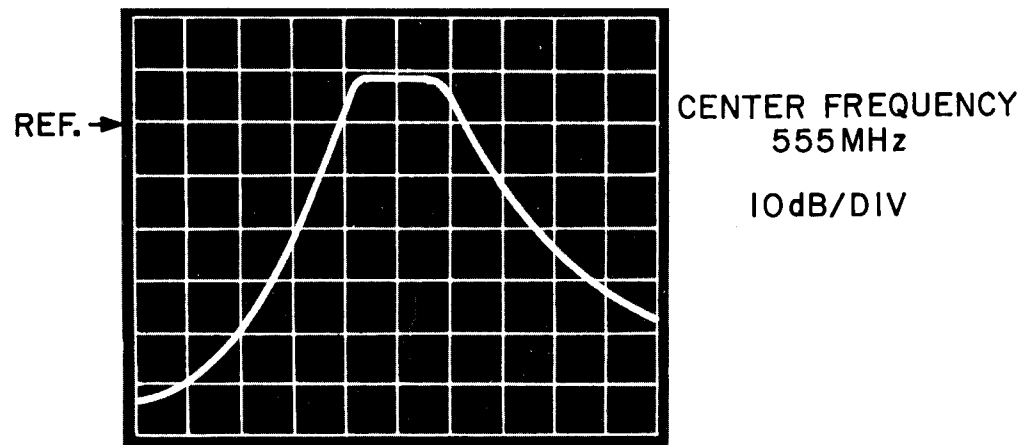

Figure 4-12. Typical Second Converter Response

- 10) Reinstall and secure all the jumpers in their proper locations and connect the test equipment as illustrated in **Figure 4-13**. Set the Wiltron to display 5 MHz per division.

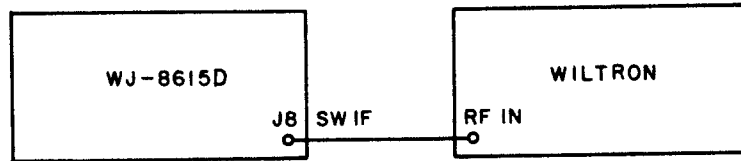

Figure 4-13. Preamplifier/Converter Sweep, Equipment Connections

- 11) Tune the WJ-8615D from 20 to 500 MHz. For each 5 MHz step, tune the Receiver 2nd LO response across the 1st LO response and verify an overall gain of 18 dB and that the 2nd LO response does not roll off excessively or drop out at any point across the receiver input range.

4.7.1.2 **IF BW Filter Amplifier (A1A12), Alignment**

- 1) Remove the Preamplifier/Converter module (A1A13) from the receiver.
- 2) Connect the equipment as illustrated in **Figure 4-14**.

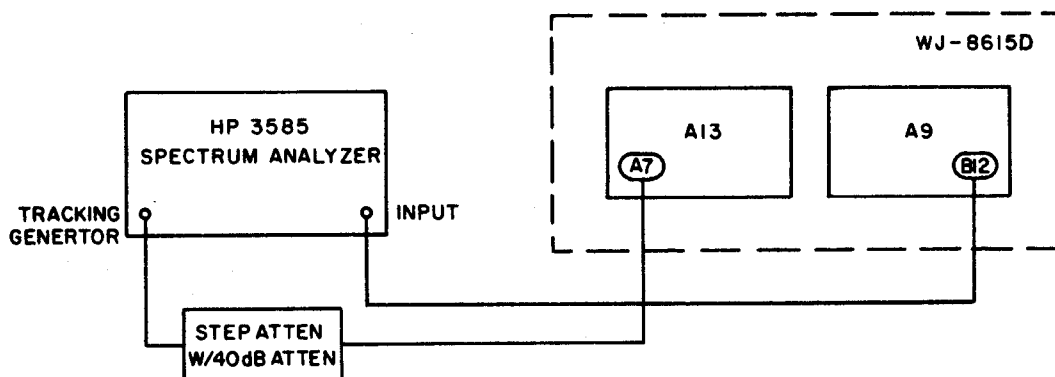

Figure 4-14. IF Amplifier, Equipment Connections

- 3) Adjust the spectrum analyzer to display the bandpass response of each bandwidth filter which is selected.

- 4) Select each receiver bandwidth and view the spectrum analyzer display. Refer to **Figure 4-15** (narrow band) and **Figure 4-16** (wide-band) for typical filter responses. Adjust (A1A12) L1 to produce the least amount of ripple for all the bandwidths.

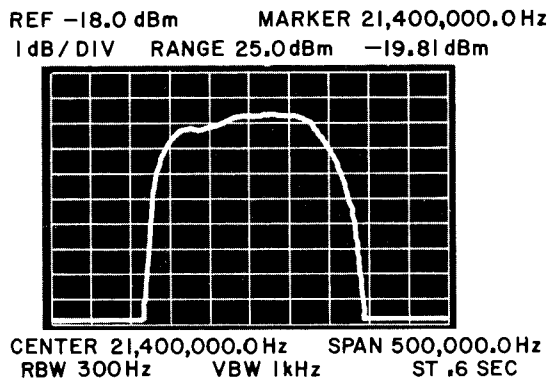

Figure 4-15. Narrow Band IF Filter Response

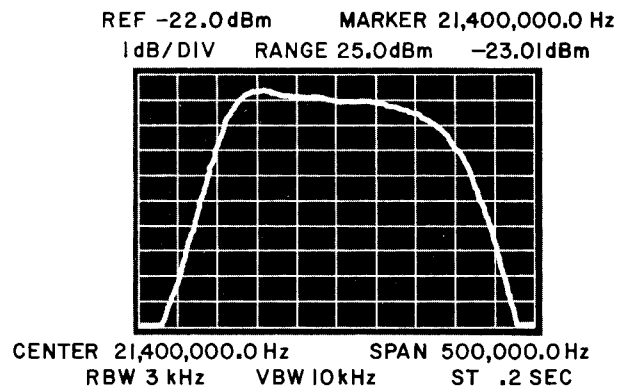

Figure 4-16. Wideband IF Filter Response

4.7.1.3 CW Demodulator (A1A11), Alignment

- 1) Set the receiver to the settings listed in **Table 4-17**, except select CW detection mode and the BFO to 0.
- 2) Connect the test equipment as illustrated in **Figure 4-17**.
- 3) Set and lock the signal generator to the same frequency as the receiver with a -60 dBm, CW output.

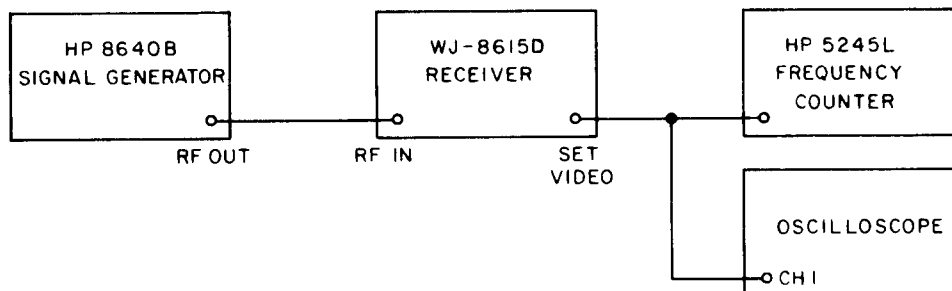

Figure 4-17. CW Demodulator Alignment, Equipment Connections

- 4) Observe the output of J5 on the frequency counter and the oscilloscope. They both should indicate approximately 0 Hz.
- 5) Depress the BFO key on the receiver and offset the BFO by 1 kHz.
- 6) Observe the frequency counter and the oscilloscope to verify the presence of a 1 kHz video signal.
- 7) Remove the AM/FM Demodulator (A1A9) module and select a bandwidth less than 300 kHz.
- 8) Connect the equipment as illustrated in **Figure 4-18**.
- 9) Set the spectrum analyzer controls to produce a 500 kHz wide sweep, centered at 21.4 MHz, with a 0 dBm reference (5 dB/DIV) at the center line of the analyzer.
- 10) Adjust (A1A11) L3 and L4 to produce the optimum response 380 kHz ($\pm 10\%$) wide, centered at 21.4 MHz, and having 14 dB (± 2 dB) of gain. Note the gain level.
- 11) Select a bandwidth greater than or equal to 500 kHz and adjust (A1A11) R36 for the same gain level noted in Step 10.

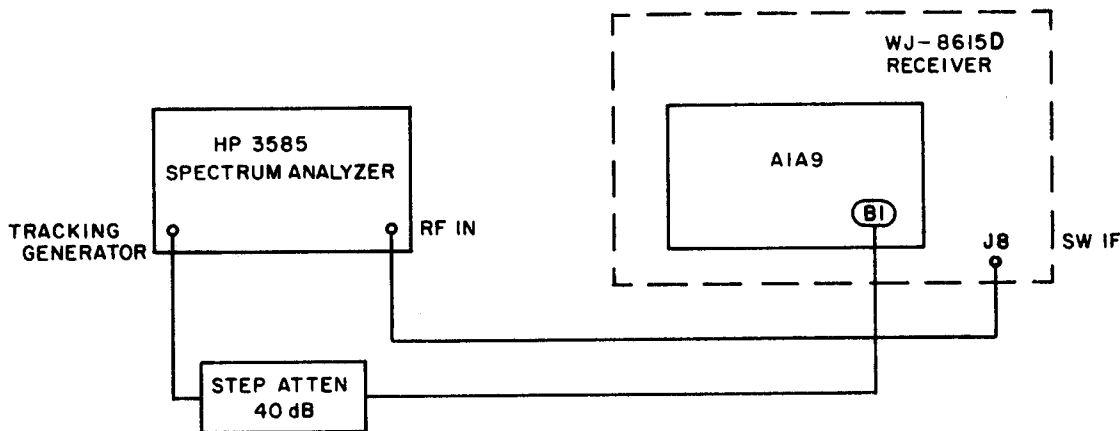

Figure 4-18. Switched IF Alignment, Equipment Connections

- 12) Set the receiver to 100 MHz CW Detection mode, Manual gain control and the narrowest bandwidth. Reinstall the AM/FM Demodulator (A1A9) module into the receiver, connect the test equipment as illustrated in **Figure 4-19**.
- 13) Set the signal generator to 100 MHz, CW and lock it on frequency.

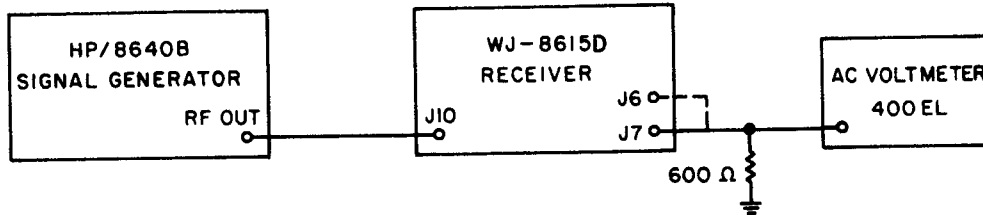

Figure 4-19. BFO Audio Alignment, Equipment Connections

- 14) On the receiver, select BFO and offset the BFO by 1 kHz. With the Audio Gain (R1) at maximum adjust (A1A11) R2 for an output level of 3.5 V rms on the voltmeter.
- 15) Connect the test equipment as illustrated in **Figure 4-20**.
- 16) Set the receiver to the parameters listed in **Table 4-17**.
- 17) Set the signal generator to 100 MHz CW at the minimum sensitivity level for the selected bandwidth (Refer to **Table 1** of **Table 1-1**.)

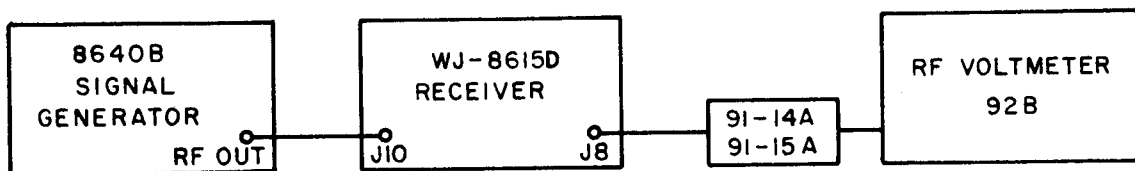

Figure 4-20. Gain Control Alignment, Equipment Connections

- 18) Adjust (A1A11) R20 until the SW IF (J8) output level on the RFVM decreases approximately 1/2 dB. Note the output level on the voltmeter.
- 19) Set the receiver RF/IF GAIN to minimum (0) and increase the signal generator output level 42 dB.
- 20) Adjust (A1A11) R13 to set the SW IF output to the same level on the RFVM as noted in Step 19.

4.7.1.4 ISB/CW (Optional) Demodulator (A1A11), Alignment

- 1) To align the optional ISB/CW Demodulator (A1A11) perform Steps 1 through 11 for the CW Demodulator module. Change the component references in Step 10 to L5 and L6, Step 11 to R36.
- 2) Perform Steps 15 through 20 of the CW Demodulator Alignment changing the values of the components adjusted in Step 18 to R57, Step 20 to R51.
- 3) Set the receiver to SSB detection mode, LSB and offset the receiver tuned frequency by 1 kHz above the signal generator frequency.
- 4) Set the signal generator output level to the minimum sensitivity level for the selected receiver bandwidth and connect the test equipment as illustrated in **Figure 4-18**.
- 5) Adjust (A1A11) R26 for 3.5 V on the ACVM at J7.
- 6) Select USB and tune the receiver 1 kHz below the signal generator.
- 7) Connect the test equipment as illustrated in **Figure 4-19**.
- 8) Adjust (A1A11) R38 to produce a 3.5 V reading on the ACVM.

4.7.1.5 AM/FM Demodulator (A1A9), Alignment

- 1) This module must be aligned in the receiver. Adjustments may be made through access holes on the backside of the module. Remove the following module:

| | |
|-------|------------------------|
| A1A13 | Preamplifier/Converter |
| A1A12 | IF BW Filter Amplifier |
| A1A11 | CW Demod SW IF |
| A1A10 | Audio Video |
- 2) Connect the test equipment as illustrated in **Figure 4-21** and ensure the green jumper wire on TC30059 is connected to pin 3 and not to pin 4. Turn the pot on TC30059 fully clockwise prior to applying power to the receiver.
- 3) On the receiver, set the manual gain control to maximum.
- 4) Adjust the sweep generator controls to produce a 2 MHz wide response with the center at 21.4 MHz, and with a -60 dBm output level. Set the F width to 2 MHz.
- 5) On the AM/FM Demodulator module (A9) adjust C46 and C57 to produce a flat and symmetrical response centered at 21.4 MHz and 650 kHz ($\pm 10\%$) wide at the 3 dB points. **Figure 4-22** illustrates the typical AM Detector response for bandwidths less than 300 kHz.

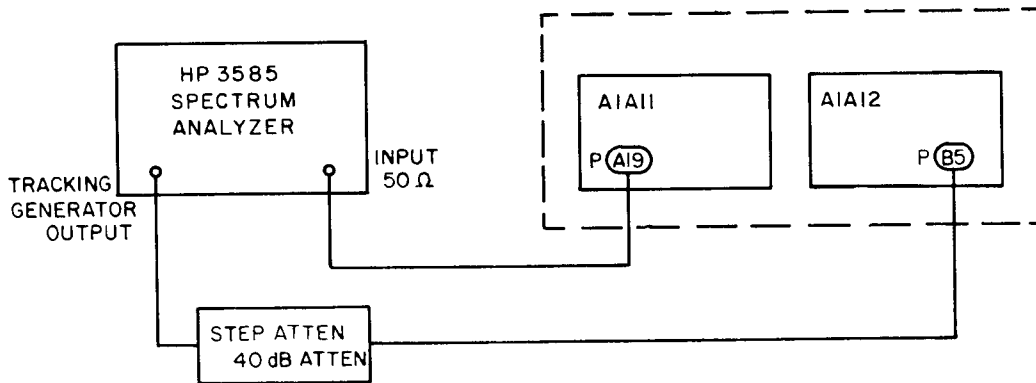

Figure 4-21. AM/FM Demodulator Alignment, Equipment Connections

- 6) Turn the receiver off and adjust the pot on TC30059 fully counter clockwise and then power the up.
- 7) Reset the sweep generator controls to display a response from 10.7 MHz to 32 MHz. Set the bandwidth select to Start/Stop with -60 dBm output level. Set the sweep generator start frequency to 10.7 MHz and the stop frequency to 32 MHz.

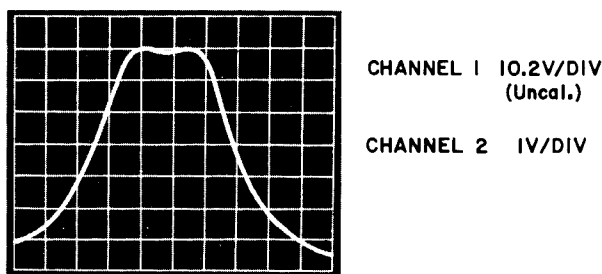

Figure 4-22. AM Detector Response
 300 kHz

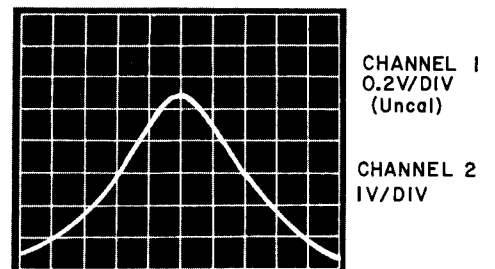

Figure 4-23. AM Detector Response
 300 kHz

- 8) Verify that the displayed bandwidth is 5.5 MHz wide ($\pm 20\%$) at the 3 dB points. **Figure 4-23** illustrates a typical AM Detector response for bandwidths 300 kHz.
- 9) Connect the test equipment as illustrated in **Figure 4-24**. Select a bandwidth greater than 300 kHz. With no signal input adjust (A1A9) R58 for a 0 V reading at J5.

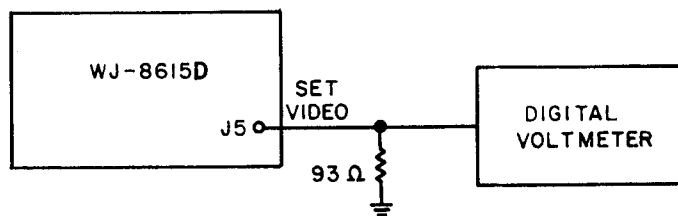

Figure 4-24. Video Alignment, Equipment Connections

- 10) Select a bandwidth from 50 to 300 kHz (50, 100 or 300) and adjust (A1A9) R-80 for a 0 V reading at J5.
- 11) Select a bandwidth less than 50 kHz (6, 10, or 20) and adjust (A1A9) R74 for a 0 V reading at J5.
- 12) Connect the test equipment as illustrated in **Figure 4-25**. Ensure the green jumper wire on TC30059 is connected to pin 4 and that the pot is fully clockwise tack solder a 50 Ω resistor load between ground and pin 19 of XA11.

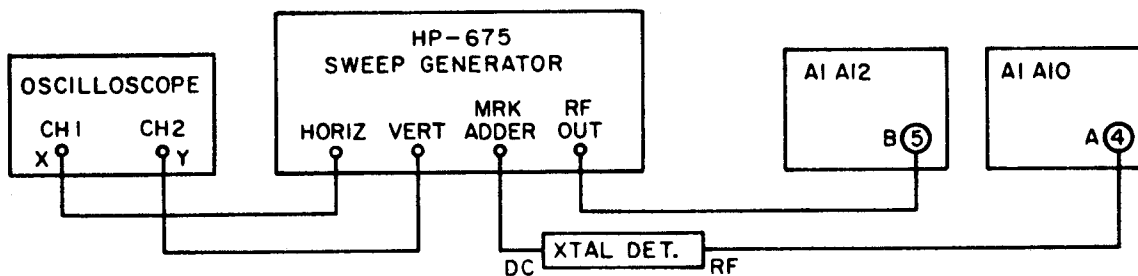
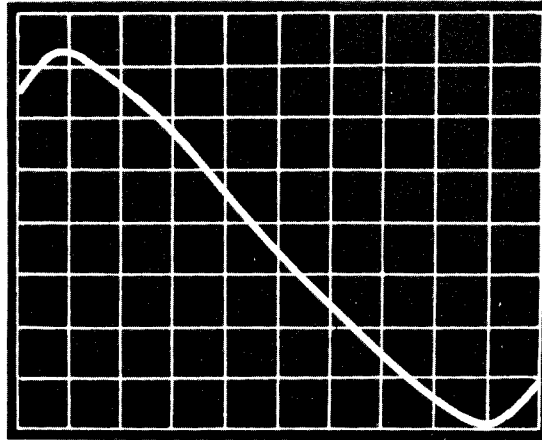

Figure 4-25. FM Discriminator Alignment, Equipment Connections

- 13) Adjust the sweep generator to produce a 21.4 MHz marker at the center of the oscilloscope. Set the F width to 100 kHz and the output level to -60 dBm.

- 14) Adjust (A1A9) L9 and L11 for the best symmetry and a zero crossover at 21.4 MHz. See **Figure 4-26** for a typical narrow-band response.



CHANNEL 1 0.2V/DIV
(Uncal)
CHANNEL 2 2V/DIV

Figure 4-26. Narrow-band FM Discriminator Typical Response

- 15) Turn the receiver off and adjust the pot on TC30059 to its midrange and turn the receiver power on. Set the sweep generator F width to 1 MHz. Adjust (A1A9) L15 (the coarse tune) and C6 (the fine tune) for maximum symmetry and a zero crossover at 21.4 MHz. See **Figure 4-27** for a typical mid-band response.

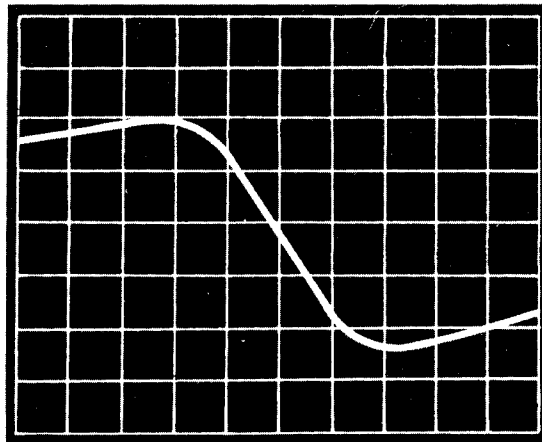

CHANNEL 1 2V/DIV
(Uncal)
CHANNEL 2 5V/DIV

Figure 4-27. Mid-band and FM Discriminator Typical Response

- 16) Turn receiver off and adjust the pot on TC30059 fully counter clockwise before applying power to the receiver again. Increase the sweep generator F width to 5 MHz. Adjust (A1A9) L13 for maximum symmetry and L14 for a 21.4 MHz zero crossover. See **Figure 4-28** for a typical wideband response.

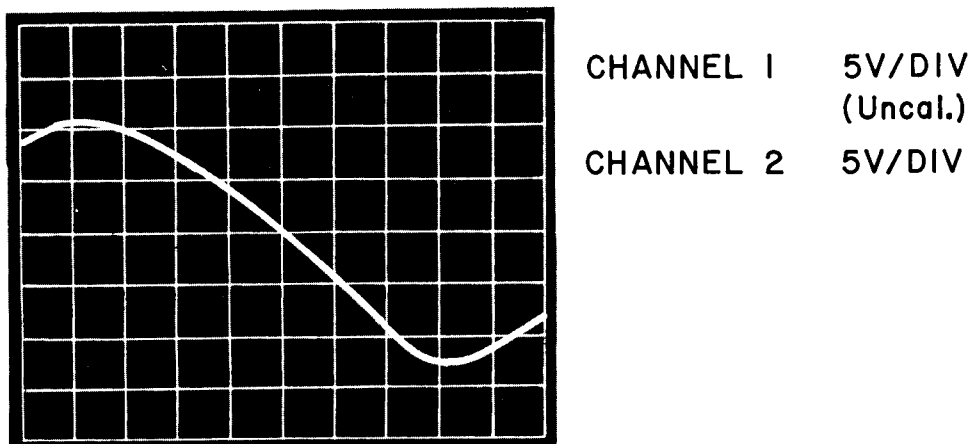

Figure 4-28. Wideband FM Discriminator Typical Response

- 17) Reinstall the modules removed in Step 1: A1A13, A1A12, A1A11, A1A10 and the Tracking Preselector (if present) unsolder the 50Ω load from XA11 and connect the equipment as illustrated in **Figure 4-29**.

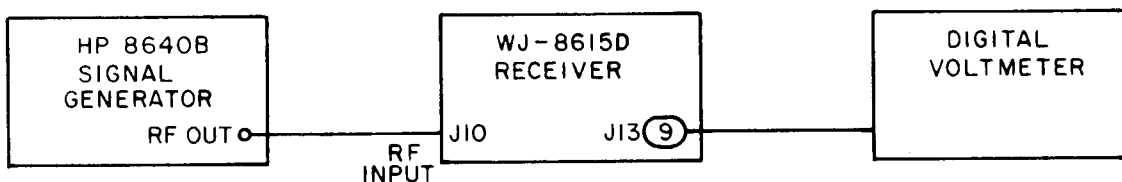

Figure 4-29. Log Video Alignment, Equipment Connections

- 18) Select the widest bandwidth installed in the receiver and set the signal generator to the sensitivity level listed in **Table 1**.
- 19) Adjust (A1A9) R13 for +0.25 Vdc at the Log Video Output (J13 pin 9).
- 20) Increase the signal generator output level 60 dB and adjust R24 for a +4.8 Vdc reading at the Log Video Output.

- 21) Disconnect the signal generator from the receiver input (J10). With no signal in, adjust R8 for +2 Vdc at A1A4 TP12.
- 22) Reset the signal generator output level to the minimum sensitivity level of the bandwidth selected (refer to **Table 1**) and reconnect the signal generator to J10 of the WJ-8615D.
- 23) Adjust (A1A9) R8 for a +2 Vdc reading on the voltmeter at A1A4 TP12.
- 24) With the receiver set to: AM detection mode, Manual gain control, and the gain control to maximum (255 displayed on the SS - dBm location), set the signal generator output to 3 dB below the minimum sensitivity level of the bandwidth selected. (Example: If the 50 kHz BW is selected set the signal generator output to -100 dBm.)
- 25) Connect the digital voltmeter to A1A4 TP12 and adjust A1A9 R21 until the voltage begins to drop. Note the DC voltage level.
- 26) Turn the receiver gain control to minimum (0 displayed), increase the signal generator output level 44 dB, and adjust A1A9 R32 to the same voltage level at A1A4 TP12 as noted in Step 25.

4.7.1.6 Audio/Video (A1A10), Alignment

- 1) Set the receiver to AM detection mode, AGC, and select the narrowest receiver bandwidth.
- 2) AM modulate the signal generator 50% at a 1 kHz rate. Set the signal generator output level to -60 dBm.
- 3) Connect the test equipment as illustrated in **Figure 4-30** and adjust R8 for 400 mV rms at the Set Video (J5).
- 4) Set the receiver to FM detection mode and select a bandwidth less than 50 kHz.

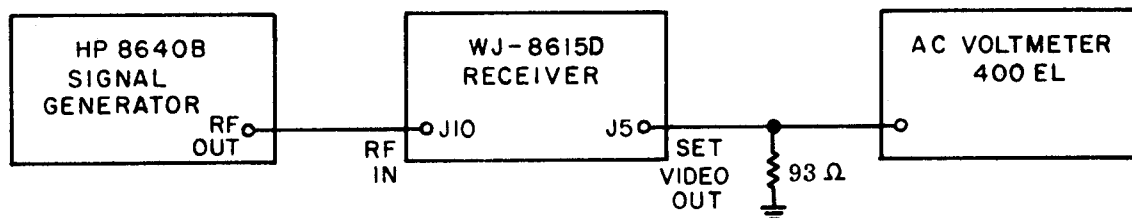

Figure 4-30. Audio/Video Alignment, Equipment Connections

- 5) Set the signal generator output level at -60 dBm and FM modulate the signal at 30% peak deviation (of the selected receiver bandwidth) at a 1 kHz rate (400 Hz rate if the receiver bandwidth is 20 kHz or less).
- 6) Adjust (A1A10) R83 for an output level of 400 mV rms at J5.
- 7) On the receiver, select a bandwidth from 50 kHz through 300 kHz. Reset the signal generator peak deviation to be 30% of the selected bandwidth.
- 8) Adjust (A1A10) R76 for a 400 mV rms output level at J5.
- 9) Select a receiver bandwidth greater than 300 kHz and reset the signal generator peak deviation to 30% of the selected bandwidth.
- 10) Adjust (A1A10) R63 for an indication of 400 mV rms on the ACVM at J5.

4.7.1.7 Reference Generator (A1A8), Alignment

- 1) Set the WJ-8615D Receiver to the Test mode, SSB detection mode and connect the test equipment as illustrated by the dashed line in **Figure 4-31**.
- 2) Observe the displayed frequency on the frequency counter and note the frequency. The displayed frequency should be 10 MHz (± 10 Hz). Note the frequency.

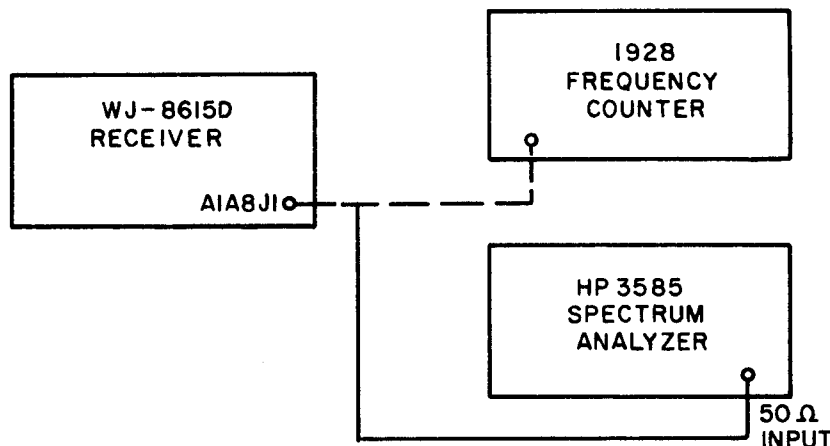

Figure 4-31. Reference Generator Verification, Equipment Connections

- 3) Connect the test equipment as illustrated in **Figure 4-31** by the solid line.

- 4) Verify that the output level at J1 is a minimum of +7 dBm. Adjust the spectrum analyzer to display the spurious products and ensure that the products are a minimum of 70 dB down from the 10 MHz reference signal.
- 5) Connect the test equipment as illustrated in **Figure 4-32** and set the signal generator to 10.01 MHz, CW, and at a 0 dBm level.

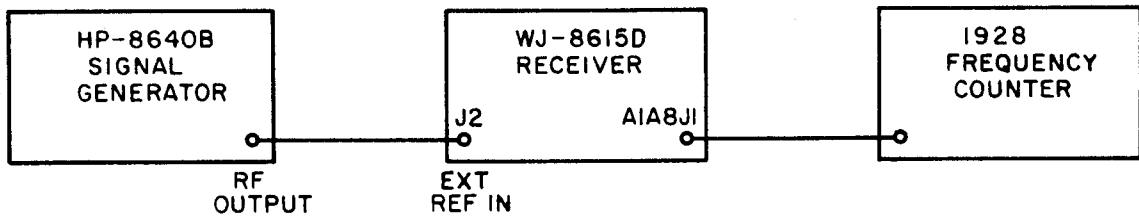

Figure 4-32. Reference Generator External Operation, Equipment Connections

- 6) Verify that the frequency indicated on the frequency counter is 10.01 MHz.
- 7) Disconnect the signal generator from the EXT REF IN (J2) and observe that the frequency counter indicates the same frequency as noted in Step 2.
- 8) Connect the test equipment as illustrated in **Figure 4-33**.

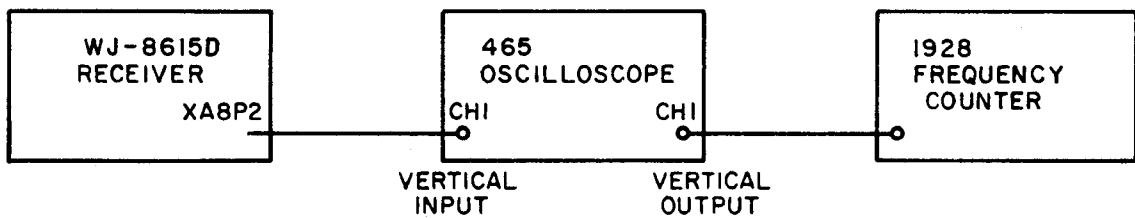

Figure 4-33. Reference Generator Waveform, Equipment Connections

- 9) Connect the oscilloscope probe to A8P2 pins 15, 17, and 13. Verify the presence and frequency of signals on the P2 connector pins for the A1A8 module.

| P2 Pin | Frequency | Amplitude | Duty Cycle |
|--------|-----------|-----------|------------|
| 15 | 1 MHz | 4 Vpk | 80% |
| 17 | 250 kHz | 4 Vpk | 50% |
| 13 | 250 kHz | 4 Vpk | 50% |

- 10) Connect a digital voltmeter to A1A8P2 pin 3 (TP5) and adjust A1A8 C18 for 2.2 V.
- 11) With the receiver in SSB detection mode, connect the oscilloscope probe to the pin (on the bottom of the motherboard, near XA11) labeled 32.1 MHz and verify the presence of a signal.
- 12) Adjust (A1A8) L8 and L9 to produce a peak output level as observed on the oscilloscope at the 32.1 MHz pin.
- 13) Set the receiver to the CW detection mode, still in Test mode, and monitor the frequency at the pin marked 21.4 MHz (near XA11).
- 14) Connect a digital voltmeter to (A1A8) P1 pin 9 and monitor to dc voltage at pin 9 for a variation from approximately 1 V - +8.5 V, when the front panel BFO is varied from +4 kHz to -4 kHz.
- 15) Connect a frequency counter at (A1A8) P1 pin 5 and adjust (A1A8) C52 to produce a variation of 8 kHz in the 21.4 MHz output frequency when the BFO is varied from +4 kHz to -4 kHz.
- 16) Set the WJ-8615D BFO to 000 on the front panel and monitor the voltage at (A1A8) P1 pin 9. The voltage should read 4.55 Vdc.
- 17) Adjust R35 for a frequency reading of 21.400 MHz at (A1A8) P1 pin 5. Ensure the voltage level on the oscilloscope is 300 mV peak-peak.
- 18) Repeat Steps 15 through 17 and readjust as required.
- 19) Set the unit to SSB detection mode, the BFO to 000, and measure the 10.7 MHz signal (near XA11 labeled 10.7 MHz). The frequency is 10.700 MHz.
- 20) Vary the BFO from +4 kHz to -4 kHz while observing the 10.7 MHz frequency. The 10.7 MHz signal varies +2 kHz to -2 kHz (10.698 - 10.702 MHz) with an output level of 300 mV peak-peak.
- 21) Connect the test equipment as illustrated in **Figure 4-34**.
- 22) Offset the BFO to produce a voltage greater than 4.55 Vdc at (A1A8) P1 pin 5 and observe the oscilloscope. Channel 1 should display a sawtooth waveform. Verify that adjusting the BFO to its limit increases the sawtooth frequency.
- 23) Offset the BFO again to produce a voltage less than 4.55 Vdc at P1 pin 5. Verify that a sawtooth waveform is displayed on Channel 2 of the oscilloscope. Verify that adjusting the BFO to its limit, in the same direction causes the displayed sawtooth repetition rate to increase.

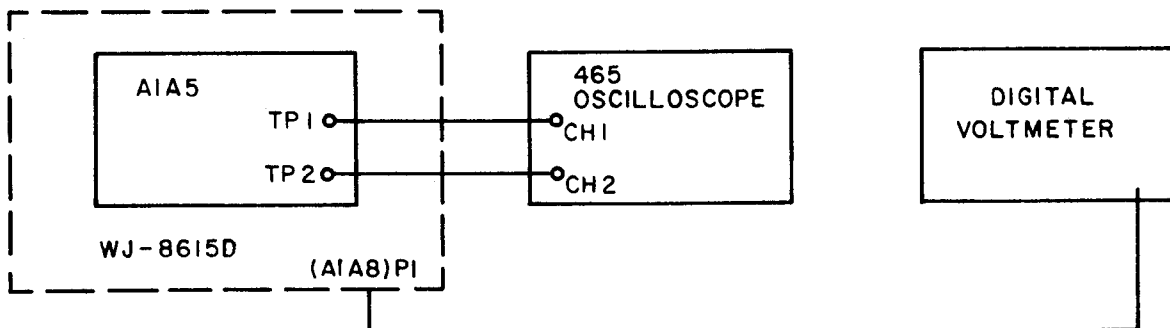

Figure 4-34. Variable BFO Alignment, Equipment Connections

- 24) Ensure the positive sawtooth peak is +3.5 V (as referenced to ground). Ensure the negative sawtooth peak is +0.4 V (as referenced to ground).
- 25) Disconnect all test equipment and reinstall all modules.

4.7.1.8 LO Synthesizer (A6 and A7), Alignment

Alignment of either the 1st LO Synthesizer or the 2nd LO Synthesizer should not be attempted due to the complexity of the test procedures and test equipment required. Alignment of the 1st LO and 2nd LO Synthesizers is not recommended. Alignment of both LO Synthesizer modules is extremely critical, requiring the utilization of an automatic test setup, and an extensive test procedure.

4.7.1.9 Analog/Digital (A1A4), Alignment

- 1) Place the WJ-8615D Receiver into the Diagnostic Test mode of operation. (Refer to **Section IV paragraph 4.5.2.5.**)
- 2) Set the COR LEVEL to display **b c** in the COR LEV display.
- 3) Depress the BANDWIDTH key to select bandwidths 1 through 5. Each time the SELECT BANDWIDTH pushbutton is depressed, hold the pushbutton in until the front panel display indicates the bandwidth and the bandwidth code.
- 4) Note the SS - dBm display for each bandwidth selected. Ensure that each bandwidth is within the limits listed in **Table 3-1.**
- 5) Adjust (A1A4) R12 to produce the best average indication for all five bandwidths.

4.7.1.10 Wideband Output Amplifier (A2), Alignment

- 1) Connect the test equipment as illustrated in **Figure 4-35**.
- 2) Set the WJ-8615D to 100 MHz and set the signal generator to 100 MHz, CW, at a -50 dBm output level.
- 3) Adjust R10 for a reading of -25 dBm on the RF voltmeter at J9.

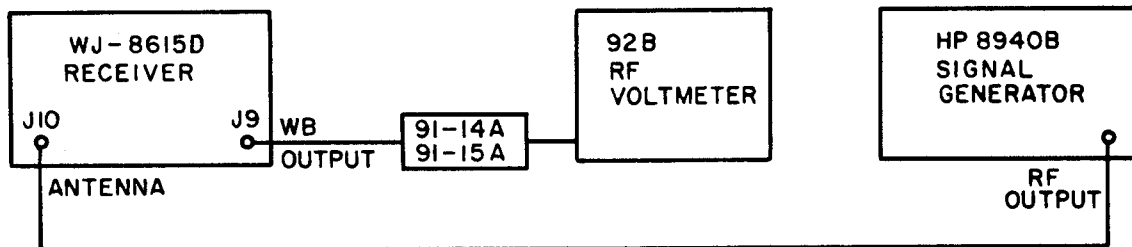

Figure 4-35. Wideband Amplifier, Equipment Connections

- 4) Reset the signal generator output level to -76 dBm and CW.
- 5) Observe the Wideband Output level, at J9, on the RF voltmeter. It should indicate no less than -30 dBm.